

OWNER'S MANUAL



485 HTO/HTOK

Hardness Taste and Odor Filter

- 1. Page 17 of this manual contains important maintenance procedures for the continued proper operation of your unit. These MUST be performed regularly for your warranty to remain valid.**
- 2. Read all instructions carefully before operation.**
- 3. Avoid pinched o-rings during installation by applying NSF certified lubricant to all seals (provided with install kit).**
- 4. This system is not intended for treating water that is microbiologically unsafe or of unknown quality without adequate disinfection before or after the system.**

Canada West
855 Park St., Unit 1
Regina, SK S4N 6M1

Canada East
490 Pinebush Rd., Unit 1
Cambridge, ON N1T 0A5

U.S.A.
56 Lightcap Rd.
Pottstown, PA 19464

9760 Mayflower Park Drive,
Suite 110
Carmel, IN 46032

4655 McDowell Rd. W
Phoenix, AZ 85035

Table of Contents

READ THIS PAGE FIRST BEFORE STARTING INSTALLATION	3
COMPONENTS & SPECIFICATIONS	
SPECIFICATION	4
SYSTEM DIMENSIONS	4
BRINE TANK DIMENSIONS	5
INSTALLATION	
UNPACKING / INSPECTION	6
ASSEMBLING BRINE TANK	8
CHECK VALVE TYPE AND VALVE SERIAL # BEFORE INSTALLATION	9
PREPARATIONS	11
INSTALLATION STEPS	12
INSTALLATION	13
OPERATION	
STARTUP INSTRUCTIONS	14
DURING REGENERATION / PLUMBING SYSTEM CLEAN-UP	16
MAINTENANCE INSTRUCTIONS AND SCHEDULE	17
REPLACEMENT	
INSPECTION AND REPLACEMENT OF PISTON ASSEMBLY AND SEAL AND SPACER KIT	19
CLEAN INJECTOR ASSEMBLY	19
SERVICING OF PARALLEL ADAPTOR	20
REPLACE METER ASSEMBLY	20
REPLACING THE BYPASS AND METER CABLE	21
REPLACE MOTOR	22
REPLACE DRAIN LINE FLOW CONTROL	22
REPLACE BRINE LINE FLOW CONTROL	22
REPLACING PCBS	23
DISPLAY REPLACEMENTS	23
AFTER SERVICING	23
PARTS BREAKDOWN	24
PARTS	
POWERHEAD	25
BYPASS	26
VALVE BODY	27
TANK AND VALVE CONNECTION	28
TROUBLE SHOOTING GUIDE	29
PROGRAMMING	
MASTER PROGRAMMING GUIDE	30

READ THIS PAGE FIRST

BEFORE STARTING INSTALLATION

- ▶ Read this manual thoroughly to become familiar with the device and its capabilities before installing or operating your Water Filter. Failure to follow instructions in this manual could result in personal injury or property damage. This manual will also help you to get the most out of your filter.
- ▶ This system is intended for use on municipal water only and its installation must comply with all State, provincial or local regulations. Check with your local public works department for plumbing and sanitation codes. In the event the codes conflict with any content in this manual the local codes should be followed. Consult your licensed plumber for installation of this system.
- ▶ This water filter is designed to operate on pressures of 30 psi to 125 psi. If the water pressure is higher than the maximum use a pressure reducing valve in the water supply line to the filter.
- ▶ This unit is capable of operating at temperatures between 40°F and 110°F (4°C - 43°C). Do not use this water filter on hot water supplies.
- ▶ Do not install this unit where it may be exposed to wet weather, direct sunlight, or temperatures outside of the range specified above.
- ▶ Avoid pinched o-rings during installation by applying (provided with install kit) NSF certified lubricant to all seals.
- ▶ Filters are commonly exposed to high levels of iron, manganese, sulfur, and sediments. Damage to pistons, seals, and or spacers within the control valve are not covered in this warranty due to the harsh environment.
- ▶ It is recommended to regularly inspect and service the control valve on an annual basis. Cleaning and or replacement of piston, seals, and or spacers may be necessary depending on how harsh the conditions are. An Annual Maintenance kit (Part # 60010565) is available for this purpose, see page 19.
- ▶ Do not use water that is microbiologically unsafe without adequate disinfection before or after this system.
- ▶ This publication is based on information available when approved for printing. Continuing design refinement could cause changes that may not be included in this publication. The manufacturer reserves the right to change the specifications referred to in this literature at any time, without prior notice.

INSTALL NOTES & SAFETY MESSAGES

Watch for the following messages in this manual:

NOTE

Do not remove or destroy the serial number. It must be referenced on request for warranty repair or replacement

NOTE: used to emphasize installation, operation or maintenance information which is important but does not present a hazard.



CAUTION!

Disassembly while under pressure can result in flooding.

CAUTION: used when failure to follow directions could result in damage to equipment or property.



WARNING!

ELECTRICAL SHOCK HAZARD! UNPLUG THE UNIT BEFORE REMOVING THE COVER OR ACCESSING ANY INTERNAL CONTROL PARTS

WARNING: used to indicate a hazard which could cause injury or death if ignored.

SPECIFICATION

Specifications	HTO/K-100	HTO/K-150	HTO/K-200	HTO/K-250	HTO/K-300
Salt Used - Per Regeneration	6.0 lbs	9.0 lbs	12.0 lbs	15.0 lbs	18.0 lbs
Water Used - Regeneration	86.4 gal	148 gal	162.4 gal	216.0 gal	224.8 gal
Hardness Removal - Grains	25,000	37,500	50,000	67,500	75,000
Tank #1 Carbon Quantity (ft3)	1.0 ft	1.50 ft	2.0 ft	2.5 ft	3.0 ft
Tank #2 Resin Quantity (ft3)	1.0 ft	1.50 ft	2.0 ft	2.5 ft	3.0 ft
Tank Size	9x48	10x54	12x52	13x54	14x65
Tank Jacket / Media Loaded	Yes	Yes	No	No	No
Brine Tank (Inches)	BTR 18.1 x 34.5 BTS 15.0 ² x34.7	BTR 18.1 x 34.5 BTS 15.0 ² x34.7	20.3 x 37.4	20.3 x 37.4	23.0 x 40.5
Salt Storage Capacity	BTS 240 lbs BTR 270 lbs	BTS 240 lbs BTR 270 lbs	350 lbs	350 lbs	420 lbs
Flow Rate @ 15 psi Pressure Drop	7.2 gpm	7.4 gpm	9.0 gpm	9.2 gpm	9.2 gpm
Flow Rate @ 25 psi Pressure Drop	10.0 gpm	10.1 gpm	11.9 gpm	12.1 gpm	12.1 gpm
Back Wash Flow Rate	4.0 gpm	5.0 gpm	7.0 gpm	8.0 gpm	10.0 gpm
Shipping Weight	154 lbs	171 lbs	214 lbs	225 lbs	232 lbs
Regeneration Type	Up Flow				
Plumbing Connections	485 Model 1" Straight NPT. 785 Model 3/4" 90° Elbows & 1" Straight NPT				
Resin Type	Aquafine 8% cation exchange resin				
Carbon Type	Catalytic Carbon				
Electrical Requirements	Input 120V 60 Hz - Output 12V 650mA				
Water Temperature	Min 39 - Max. 100° F				
Water Pressure	Min. 20 - Max. 125 psi				

Working Temperature: This unit must be operated at temperatures between 40°F and 110°F (4°C - 43°C).

Working Pressure: This water softener must be operated on pressures between 30 psi to 125 psi. If the water pressure is higher than 125 PSI, use a pressure reducing valve in the water supply line to the softener.

Voltage = 120V / 60 Hz
Pipe Size = 3/4" and 1"

- At the stated service flow rates, the pressure drop through these devices will not exceed 15 psig.
- The manufacturer reserves the right to make product improvements which may deviate from the specifications and descriptions stated herein, without obligation to change previously manufactured products or to note the change.

* Do not use water that is microbiologically unsafe without adequate disinfection before or after the system.

Peak flow rates intended for intermittent use only (10 minutes or less) and are for residential applications only. Do not use peak flow rate for commercial applications or for a continuous rate when treated water supplies are geothermal heat pump, swimming pool, etc.

For satisfactory operation, the pumping rate of the well system must equal or exceed indicated backwash flow rate.

All units come with plastic bypass

Maximum Iron = 1.5 ppm

Maximum Hydrogen Sulfide = 0.0 ppm

Maximum Manganese = .75 ppm

pH = 6.5 to 8.5

SYSTEM DIMENSIONS

Models	A (Inches)	B (Inches)
HTO/K-100	58	9
HTO/K-150	64	10
HTO/K-200	62	12
HTO/K-250	64	13
HTO/K-300	75	14

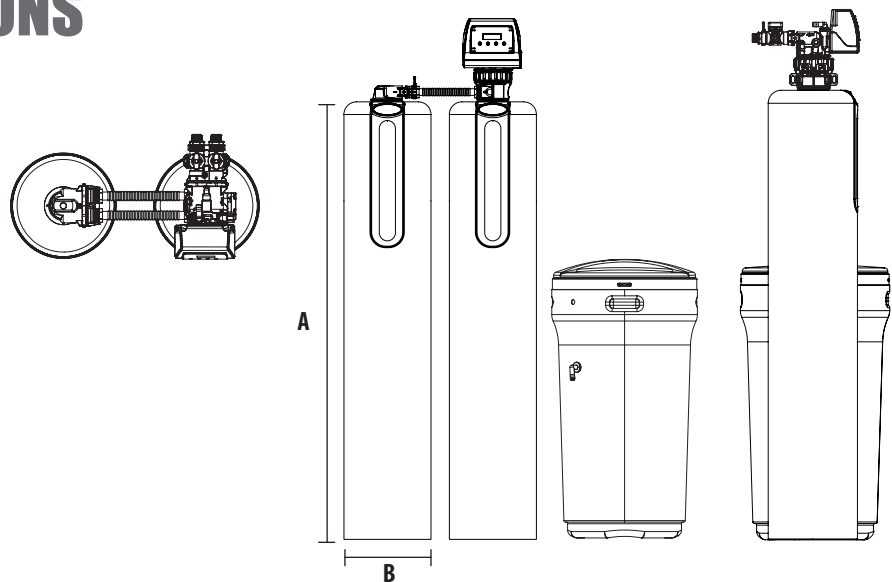

BRINE TANK DIMENSIONS

Model	Liquid Volume		Tank Dimensions (inches)	5 Pack Carton Dimensions (inches)	Salt Capacity		5 Pack Carton Shipping Weight	
	US Gal	Liters	L x W x H	L x W x H	Lbs	Kg	Lbs	Kg
Brine Tanks								
BTR-100	29.5	111.5	18.1 x 34.7	18.9 x 18.9 x 65.6	270.0	122.2	52.8	23.9
BTR-145	42.3	159.7	20.3 x 37.4	21.9 x 21.9 x 72.2	385.0	174.2	65.6	29.8
BTR-200	53.0	200.3	23.0 x 40.5	24.6 x 24.6 x 84	700.0	316.7	125.0	56.6

* All brine tanks come with salt grid, safety float and brine well

BTR100

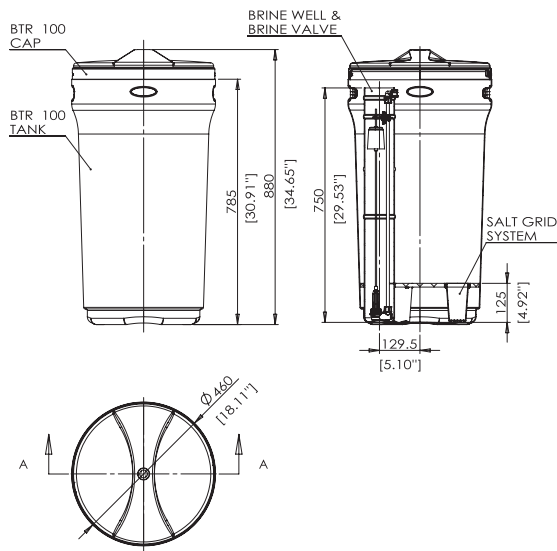

BTR145

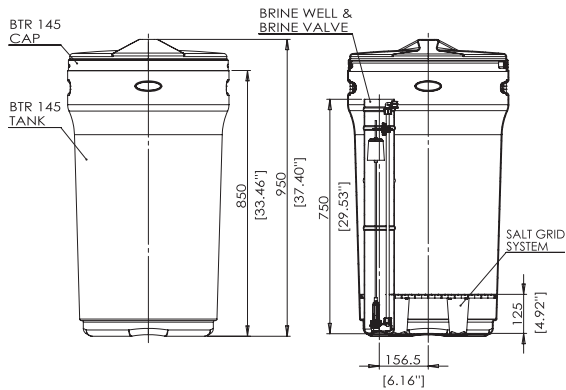

BTR200

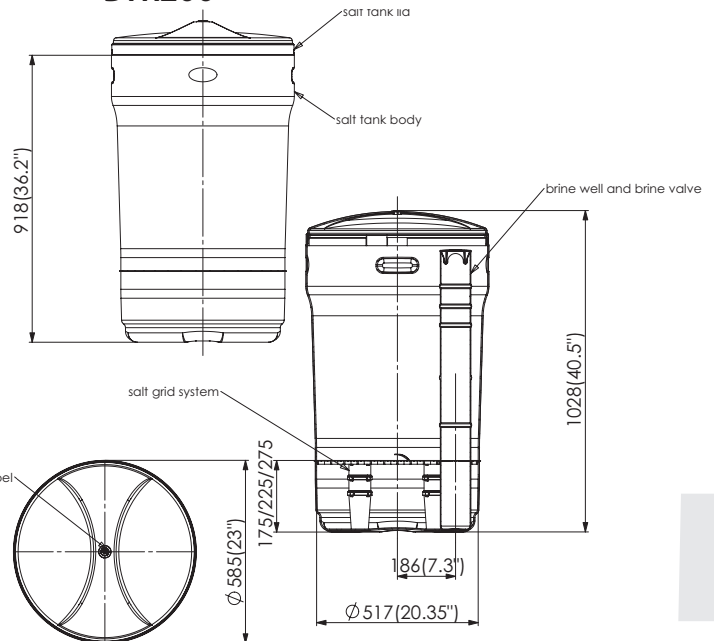

UNPACKING / INSPECTION

Be sure to check the entire unit for any shipping damage or parts loss. Also note damage to the shipping cartons. Contact the transportation company for all damage and loss claims. The manufacturer is not responsible for damages in transit.

Small parts, needed to install the filter, are in a parts box. To avoid loss of the small parts, keep them in the parts bag until you are ready to use them.

What is included in the box?

For Models HTO/K-100, HTO/K-150 and HTO/K-200, you will expect the following. Shipping Carton Quantity – 2

1. Control Valve
2. Tank 2 c/w Parallel Adaptor
3. Parts Box
4. Owners Manual
5. Drain Hose & Clamp (Not included in some brands)
6. Parts Bag
7. Tank 1 c/ Adaptor

1. Control Valve →

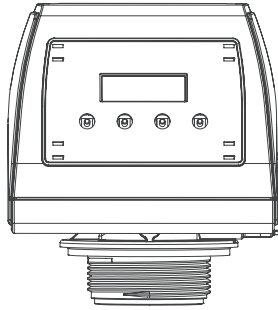

There are 8 Red clips. Please check to make sure you have all of them.

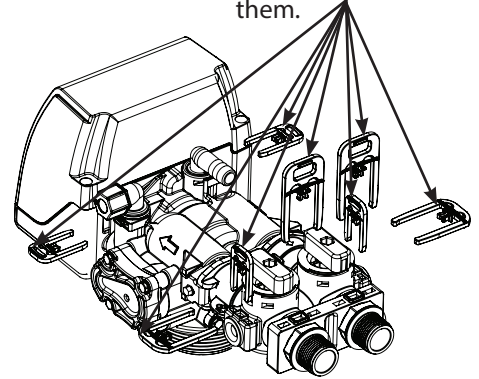

3. Parts Box

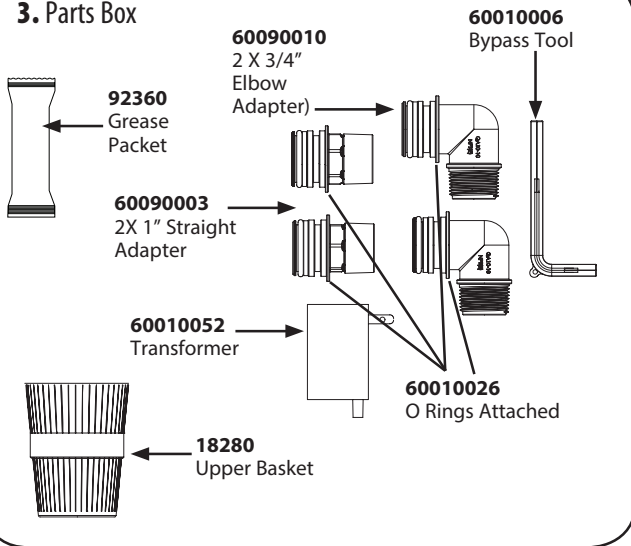

7. Tank 1 C/w Adaptor →

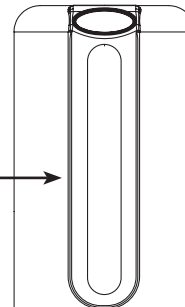

Tank 1
Media:
CARBON

Parallel Adaptor



2. Tank 2 C/w Parallel Adaptor

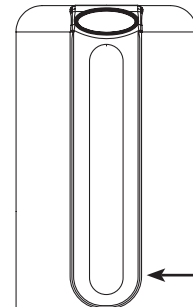

Tank 2
Media:
RESIN

6. Parts Bag

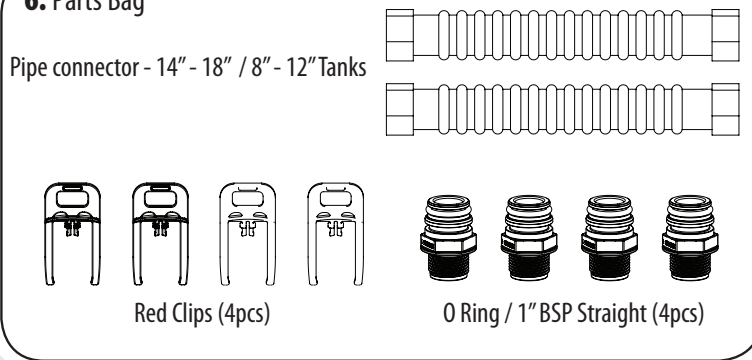

6

For Models HTO/K-250 and HTO/K-300 models , the media and Control Valve is packaged separately in carton and bags

What is included with HTO/K-250 and HTO/K-300 models?

1. Tank #1 c/w Adaptor
2. Tank #2 C/w Parallel Adaptor
3. Qty 6 of Media Boxes
4. Drain Line and Hose Clamp (Not Included with some models)
5. Control Valve with Parts Box
6. Parts Bag

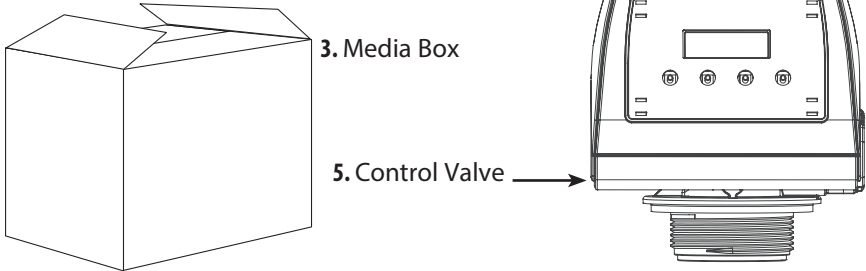

There are 8 Red clips. Please check to make sure you have all of them.

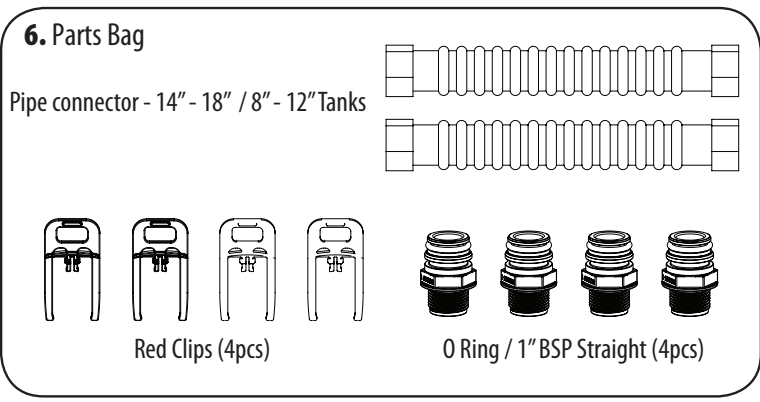
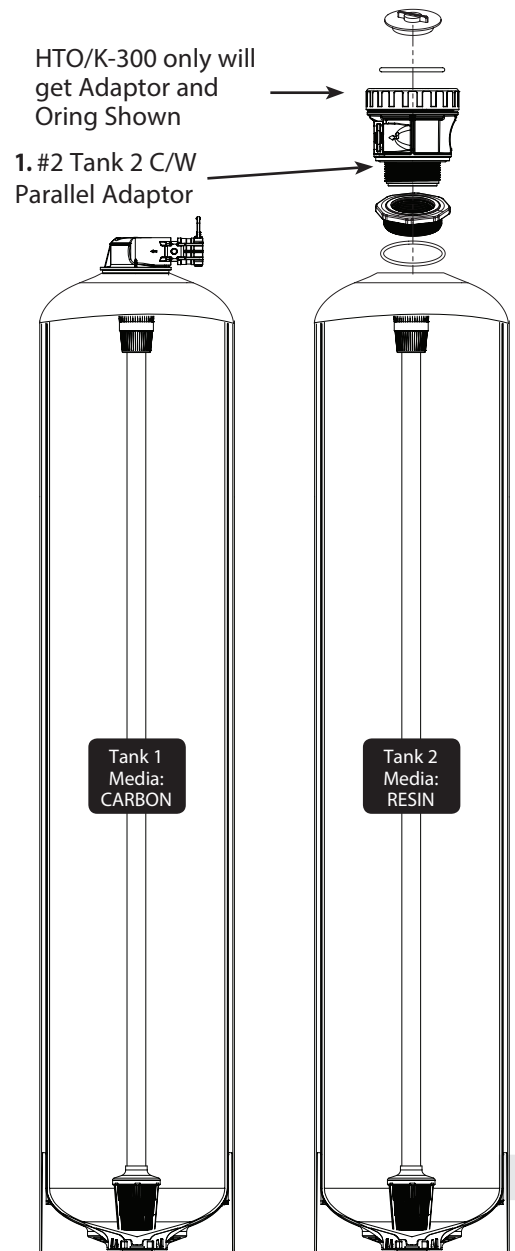
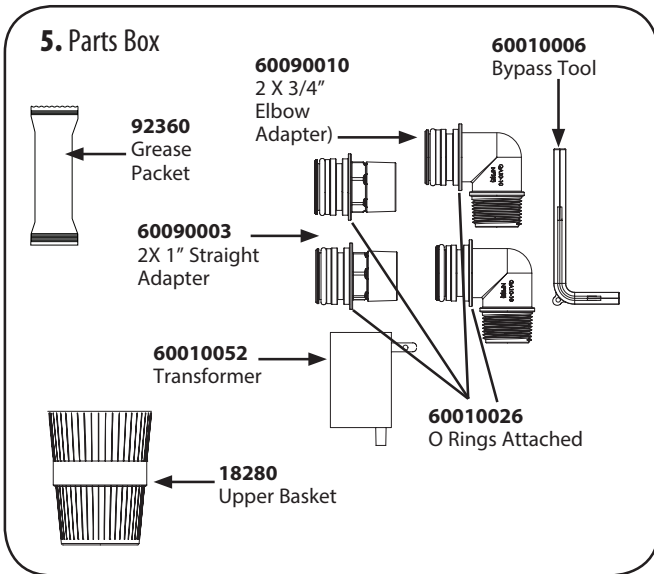
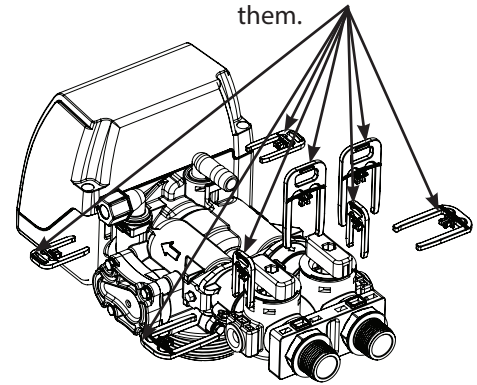

Make sure the bypass is attached well to the control valve. Connect the straight or elbow connectors to the bypass with red clips. Connect the inlet and outlet of the water filter to the plumbing of the house. The control valve must not be submitted to temperatures above 43°C (110°F). When sweat fittings are used, to avoid damaging the control valve, solder the threaded copper adapters to the copper pipe and then, using Teflon tape, screw the assembly into the bypass valve.

Do not use pipe thread compound as it may attack the material in the valve body.

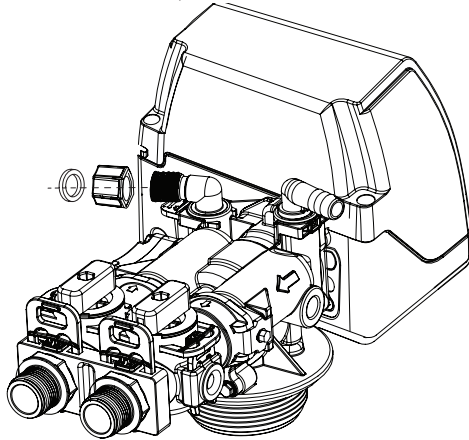

Pipe connector - 14" - 18" / 8" - 12" Tanks

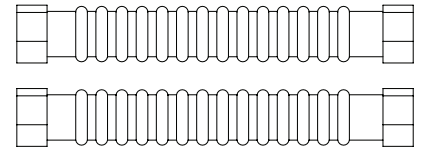

6. Install the connectors with fitting as shown. Also install the valve on the parallel adaptor.

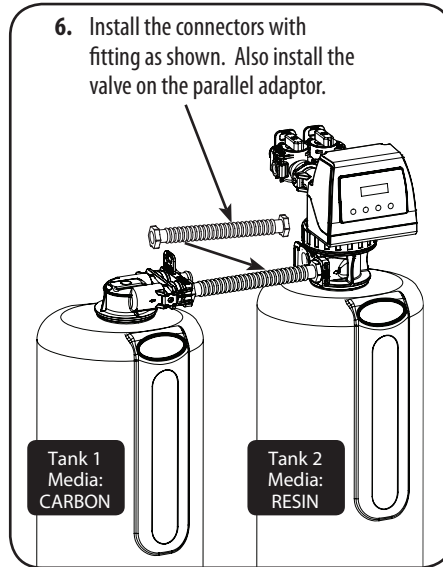

Make sure all red clips are firmly in place before applying pressure

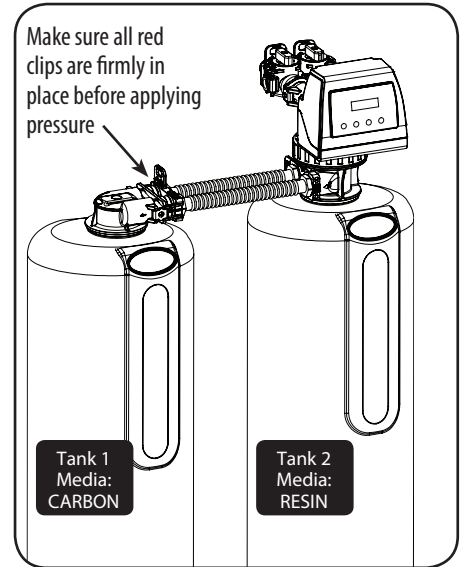

ASSEMBLING BRINE TANK

a) Attach the three brine grid legs to grid plate. The legs will snap on to the tabs of the salt plate making a "click" sound. For square brine tank there are four legs.)

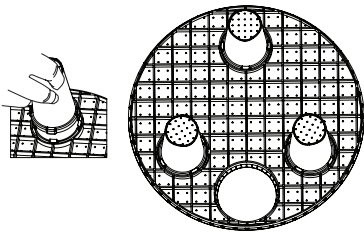

b) Insert the brine well assembly inside the grid plate as well below.

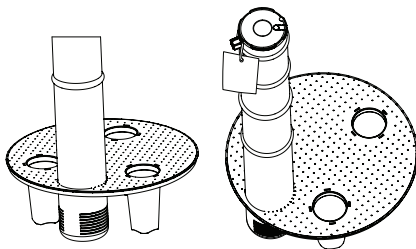

c) Drop the brine grid with brine well inside the brine tank such that the nut fitting faces the hole on the brine tank. Then press the grid evenly inside the brine tank until the brine grid legs touches the bottom of the brine tank.

IMPORTANT:
IN ROUND BRINE TANK, IT IS IMPORTANT TO ALIGN THE HANDLE TO THE BRINE WELL AS SHOWN

The hole in the brine tank should line up with the brine line as shown.

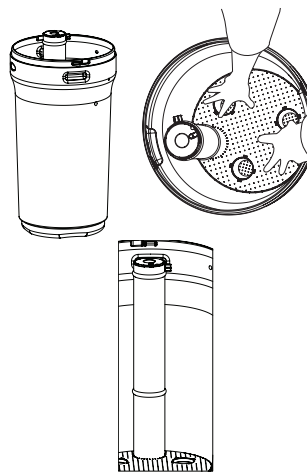

d) Take the brine tube and insert the nut and plastic sleeve as shown below.

Insert Sleeve

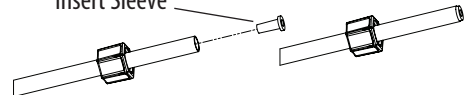

e) Insert the tube in the float assembly elbow and hand tighten the nut. In many cases the brine line already come installed from the factory. Leave the other end of the brine line tube inside the brine tank

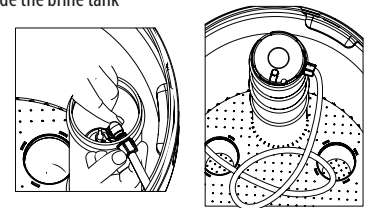

f) For installation of brine tank at the installation site, pull the other end of the brine tube from the hole on the brine tank. The completed assembly is shown below.

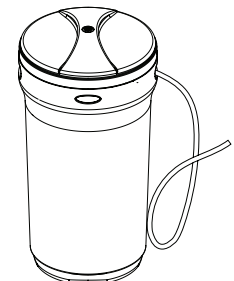

6. Attaching Brine Tubing to the Brine Line of the Valve

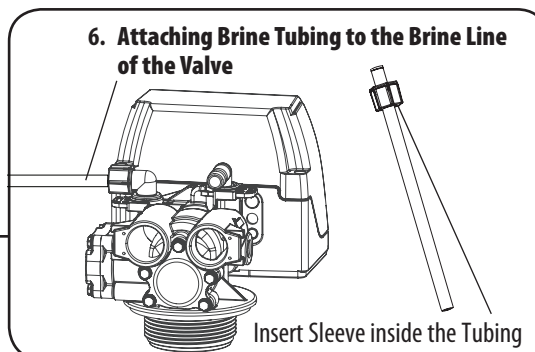

Insert Sleeve inside the Tubing

Check Valve Type and Valve Serial

Check to make sure Valve Type is Upflow (UF) (left Sticker shown below). The right Sticker shows the serial # of the control valve. The middle Sticker is dataplate which provides information of Serial # and Date of Manufacture of complete system. Both Serial # labels are important for troubleshooting.

Please record these numbers for future use on page 23 in the maintenance section.

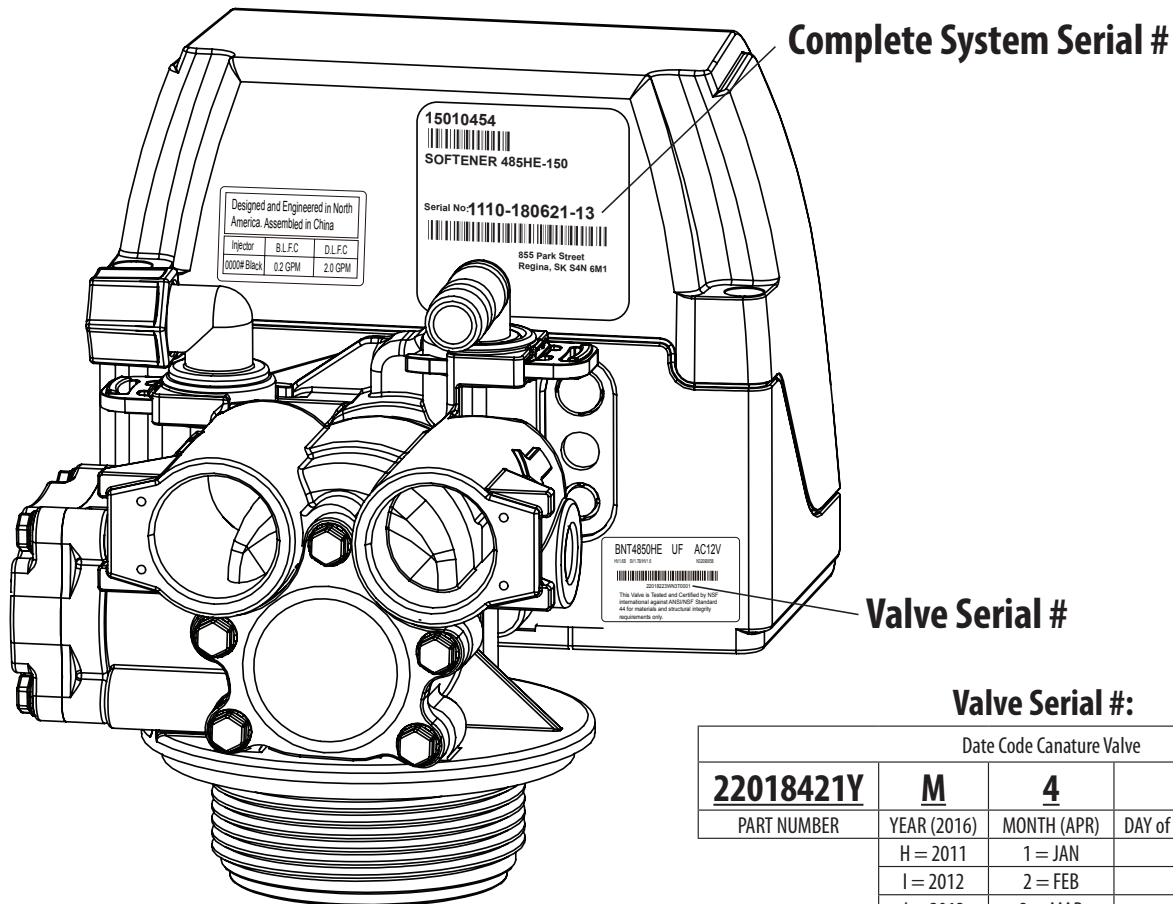

Valve Serial #:

Date Code Canature Valve				
22018421Y	M	4	L	0001
PART NUMBER	YEAR (2016)	MONTH (APR)	DAY of MONTH (21)	BATCH NUMBER
	H = 2011	1 = JAN	1	
	I = 2012	2 = FEB	2	
	J = 2013	3 = MAR	3	
	K = 2014	4 = APR	4	
	L = 2015	5 = MAY	5	
	M = 2016	6 = JUN	6	
	N = 2017	7 = JUL	7	
	O = 2018	8 = AUG	8	
	P = 2019	9 = SEP	9	
	Q = 2020	A = OCT	A = 10	
		B = NOV	B = 11	
		C = DEC	C = 12	
			D = 13	
			E = 14	
			F = 15	
			G = 16	
			H = 17	
			I = 18	
			J = 19	
			K = 20	
			L = 21	
			M = 22	
			N = 23	
			O = 24	
			P = 25	
			Q = 26	
			R = 27	
			S = 28	
			T = 29	
			U = 30	
			V = 31	

BEFORE INSTALLATION

Make sure you have a copy of your most recent water test results. If your water has not been tested previously you can contact your supplier of this product to obtain a water sample bottle to be sent to one of our facilities for a free analysis. **It is important that this product not be installed until you have this information.**

In all cases where metal pipe was originally used and is later interrupted by poly pipe or the Noryl bypass valve or by physical separation, an approved ground clamp with no less than #6 copper conductor must be used for continuity, to maintain proper metallic pipe bonding.

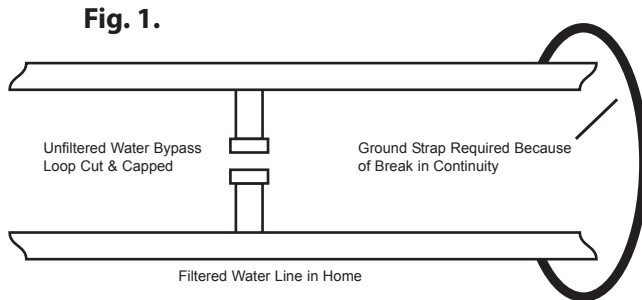

Inspecting and Handling Your HT0/K Filter*

Inspect the equipment for any shipping damage. If damaged, notify the transportation company and request a damage inspection. Damage to cartons should also be noted.

Handle the filter unit with care. Damage can result if it is dropped or set on sharp, uneven projections on the floor.

Do not turn the filter unit upside down.

To Insure this Product Functions Properly:

Your feed water line size to the unit must be a minimum of 3/4 inch with an operating pressure of no less than 30 psi and no more than 125 psi.

MECHANICAL:

Do not use petroleum based lubricants such as petroleum jelly, oils or hydrocarbon based lubricants. Use only 100% silicone lubricants (grease packet provided in parts kit). All plastic connections should be hand tightened only. Teflon tape may be used on connections that do not use an O-ring seal. Do not use pliers or pipe wrenches except where indicated by Nut shape (eg. pipe adapters) All plumbing must be completed according to local codes. Soldering connections should be done before connecting any pieces to the pipe as excessive heat can damage them.

Tools Required for Installation:

NOTE: We recommend installation only be completed by a competent installer or plumbing professional to insure this product is installed in accordance with local plumbing codes.

- ▶ Two adjustable wrenches
- ▶ Additional tools may be required if modification to home plumbing is required.
- ▶ Plastic inlet and outlet fittings are included with the filter. To maintain full valve flow, 3/4" or 1" pipes to and from the filter fittings are recommended. You should maintain the same, or larger, pipe size as the water supply pipe, up to the filter inlet and outlet.
- ▶ Use copper, brass, or PEX pipe and fittings.
- ▶ Some codes may also allow PVC plastic pipe.
- ▶ ALWAYS install the included bypass valve, or 3 shut-off valves. Bypass valves let you turn off water to the filter for repairs if needed, but still have water in the house pipes.
- ▶ 5/8" OD drain line is needed for the valve drain. A 10' length of hose is not included with some brands.

NOTE

All government codes and regulations governing the installation of these devices must be observed.



CAUTION!

If the ground from the electrical panel or breaker box to the water meter or underground copper pipe is tied to the copper water lines and these lines are cut during installation of the Noryl bypass valve and/or poly pipe, an approved grounding strap must be used between the two lines that have been cut in order to maintain continuity. The length of the grounding strap will depend upon the number of units being installed and/or the amount of copper pipe being replaced with plastic pipe.

See Fig. 1.

NOTE

Check your local electrical code for the correct clamp and cable size.

NOTE

If a severe loss in water pressure is observed when the filter unit is initially placed in service, the filter tank may have been laid on its side during transit. If this occurs, backwash the filter to "reclassify" the media.

*NOTE

Due to transportation and climatic conditions all connections including the valve to the tank need to be checked at time of installation and tightened if necessary.

PREPARATIONS

- Media Installation (When Necessary).** Models larger than 2.0 CF of media are shipped with separate media in pails or boxes. Models lower than 1.5 CF of media come loaded with media and this step can be skipped for new installation.



The unit should be depressurized before installing or replacing media

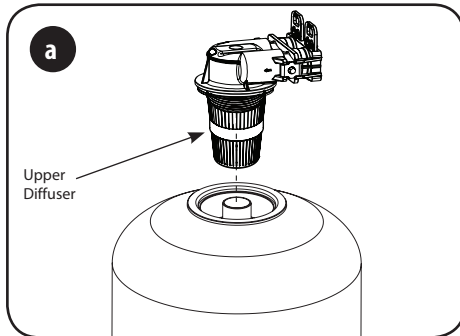

- Remove the adaptor from the mineral tank. Grease the bottom oring of the adaptor with silicone grease provided

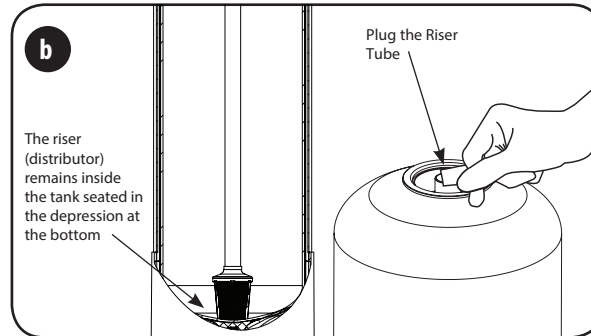
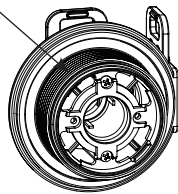

- Temporarily plug the open end of the riser tube to ensure that no resin or gravel falls down into the distribution. The riser (distributor) remains inside the tank seated in the depression at the bottom. Plug tube with a tape. Remove after media is loaded.

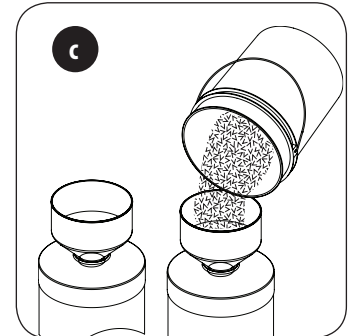

- Fill support bed first. The media will not always spill down inside the tank and may need to be swept inside. The large funnel (sold separately) makes filling the tank easier and neater. (Or an empty 1 gallon or 4 liter container with the bottom cut out makes a good funnel.)

Locate Water Conditioning Equipment Correctly

Select the location of your filter tank with care. Various conditions which contribute to proper location are as follows:

- Locate as close as possible to the water supply source.
- Locate as close as possible to a floor or laundry tub drain.
- Locate in correct relationship to other water conditioning equipment. if closer than 10 feet please install check valve in accordance with local plumbing codes.
- Conditioners should be located in the supply line before the water heater. Temperatures above 110°F (43°C) will cause damage to conditioners.
- Do not install a filter or filter in a location where freezing temperatures occur. Freezing may cause permanent damage to this type of equipment and will void the factory warranty.
- Allow sufficient space around the unit for easy servicing.
- Keep the filter out of direct sunlight. The sun's heat may soften and distort plastic parts.

NOTE

Never make a direct connection into a waste drain. A physical air gap of at least 1.5" should be used to avoid bacteria and wastewater travelling back through the drain line into the softener.

NOTE

The unit is not ready for service until you complete the start-up instructions, page 15.

Make sure both brass and plastic nuts are tightened well

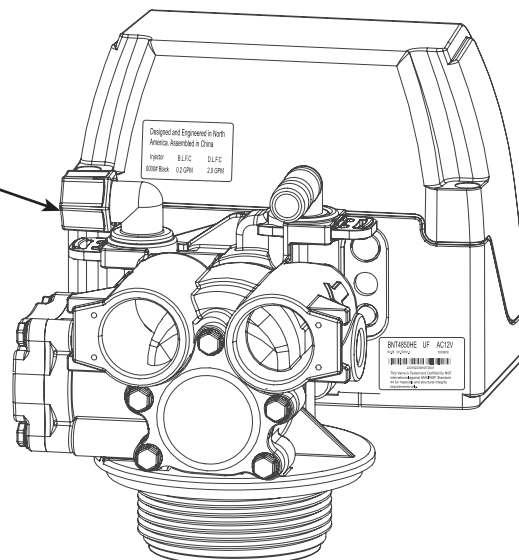

INSTALLATION STEPS

1. Determine the best location for your water filter, bearing in mind the location of your water supply lines, drain line and 120 volt AC electrical outlet. Subjecting the filter to freezing or temperatures above 43°C (110°F) will void the warranty.

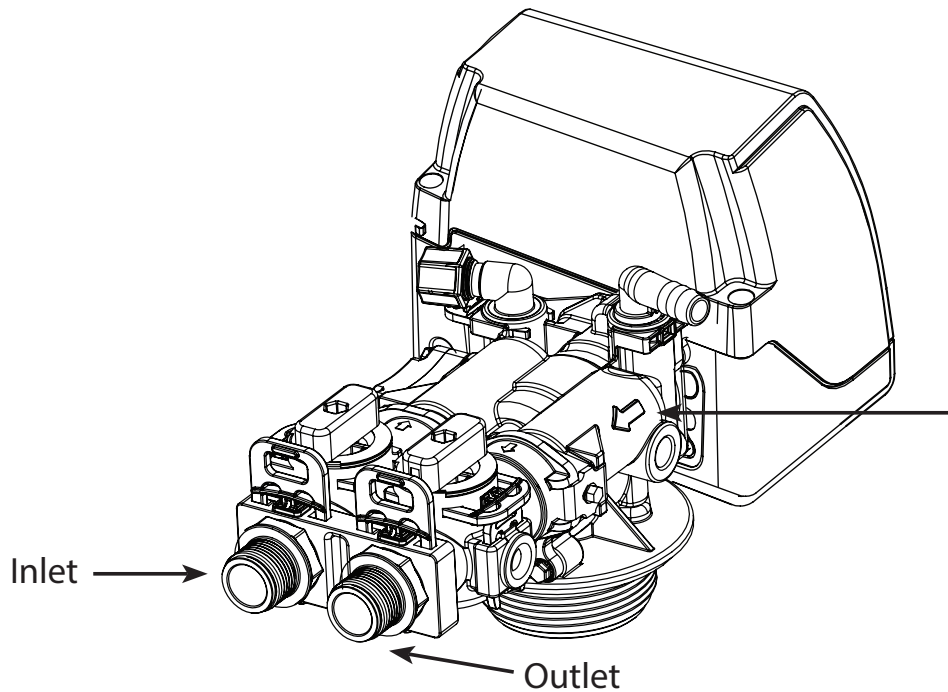

Please notice the inlet and outlet arrows on the valve as shown here to determine the position of the equipment

Facts to Remember When Planning Your Installation

1. All installation procedures must conform to local and state or provincial plumbing codes.
2. Outside faucets used to water lawns and gardens should not supply untreated water, replace untreated water with feed water to the unit. If necessary to do this please install check valve, see page 14. A new water line is often required to be connected to supply untreated water to the inlet of the water filter and to the outside faucets.
3. Make sure the bypass is attached well to the control valve. Connect the straight or elbow connectors to the bypass with red clips. Connect the inlet and outlet of the water filter to the plumbing of the house. The control valve must not be submitted to temperatures above 43°C (110°F). When sweat fittings are used, to avoid damaging the control valve, solder the threaded copper adapters to the copper pipe and then, using Teflon tape, screw the assembly into the bypass valve.
Do not use pipe thread compound as it may attack the material in the valve body.
4. Apply Teflon Tape and Orings to the fittings
5. Connect Filter to the house plumbing. Any solder joints near the valve must be done before connecting any piping to the valve. Always leave at least 6" (152 mm) between the valve and joints when soldering pipes that are connected to the valve. Failure to do this could cause damage to the valve.
6. **Drain Line connection:** Using Teflon tape, screw the 1/2" hose barb and attach oring into the drain port in the valve. Attach 1/2" drain hose (Supplied with some models and brands) to the hose barb and tighten securely with a hose clamp (Supplied with some models and brands). Run the drain line to a floor drain or a laundry drain. Complete any necessary plumbing.
7. Using the Allen Key (included), place the unit in the bypass position. Slowly turn on the main water supply. At the nearest cold treated water tap nearby remove the faucet screen, open the faucet and let water run a few minutes or until the system is free of any air or foreign material resulting from the plumbing work.
8. Make sure there are no leaks in the plumbing system before proceeding. Close the water tap when water runs clean.
9. Open the brine tank / cabinet salt lid and add water until there is approximately 3" (75 mm) of water in the tank. Do not add salt to the brine tank at this time.

NOTE

If the plumbing system is used as the ground leg of the electric supply, continuity should be maintained by installing ground straps around any nonconductive plastic piping used in installation.

NOTE

Before starting installation, read page 16, Plumbing System Clean-Up, for instructions on some procedures that may need to be performed first.

INSTALLATION

Connect Filter to the house plumbing. Any solder joints near the valve must be done before connecting any piping to the valve. Always leave at least 6" (152 mm) between the valve and joints when soldering pipes that are connected to the valve. Failure to do this could cause damage to the valve.

Correct Installation of the Check Valve: Install 1" check valve on inlet of bypass valve. *The check valve needs to be installed at the highest possible level of the plumbing line to avoid air trap. Please see an example below:*

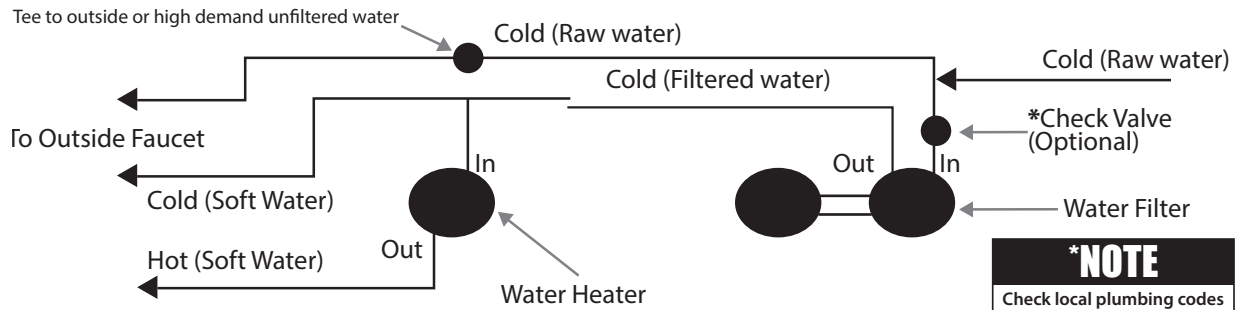

***NOTE**
Check local plumbing codes in regards to requirements for use of Check Valve or back flow prevention or vacuum breaker

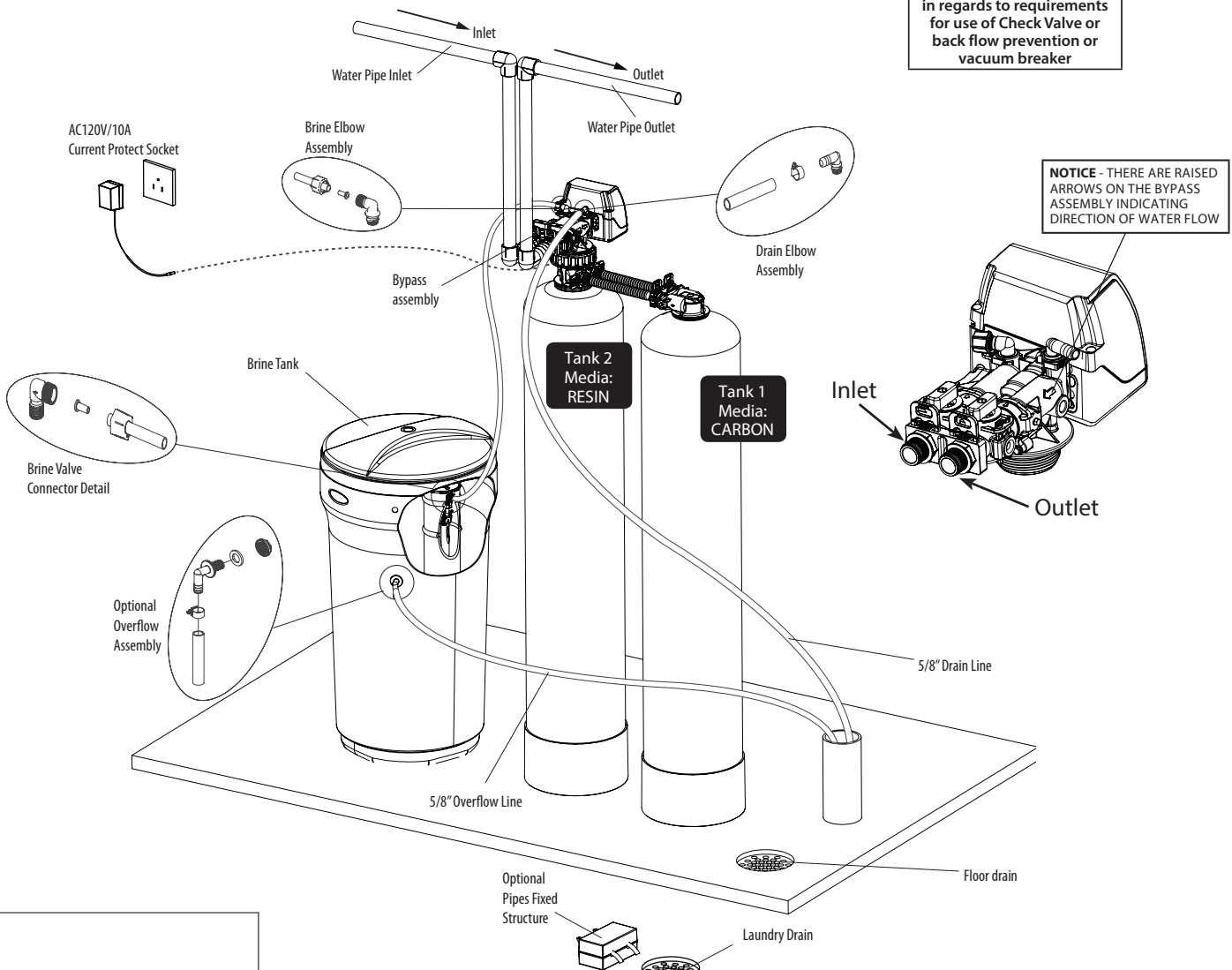

NOTICE - THERE ARE RAISED ARROWS ON THE BYPASS ASSEMBLY INDICATING DIRECTION OF WATER FLOW

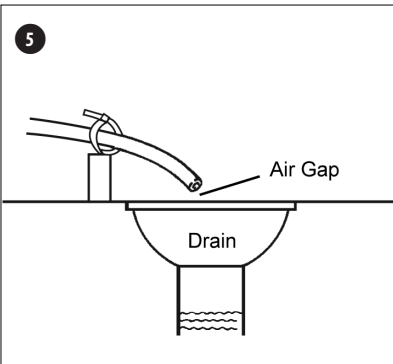

CAUTION!
Never insert drain line directly into a drain, sewer line, or trap. Always allow an air gap between the drain line and the wastewater to prevent the possibility of sewage being back-siphoned into the conditioner.

NOTE
Waste connections or drain outlet shall be designed and constructed to provide for connection to the sanitary waste system through an air-gap of 2 pipe diameters or 1 inch (22 mm) whichever is larger.

STARTUP INSTRUCTIONS

1. Connect the Transformer to the Valve

Plug the 12-volt transformer into a 120 VAC 60 Hz outlet.

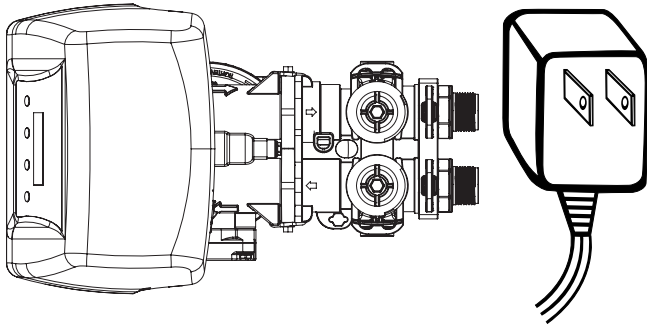

2. Add Water to Brine Tank

Open the brine tank /cabinet salt lid and add water as per the chart below. Do not add salt to the brine tank at this time.

- BTR-100 - 2.5 US Gallons**
- BTR-145 - 3.25 US Gallons**
- BTR-200 - 5.5 US Gallons**

CAUTION!

FAILURE TO FOLLOW STEP 2 WOULD DEplete THE RE-SERVE CAPACITY OF RESIN AND RESULT IN HARDNESS LEAKAGE. IN CASE STEP 2 IS MISSED, THEN SOFTENER SHOULD BE REGENERATED TWICE OR THRICE BACK TO BACK TO RESTORE THE RE-SERVE CAPACITY OF RESIN

3. Screen Display

Familiarize with Button Configuration:

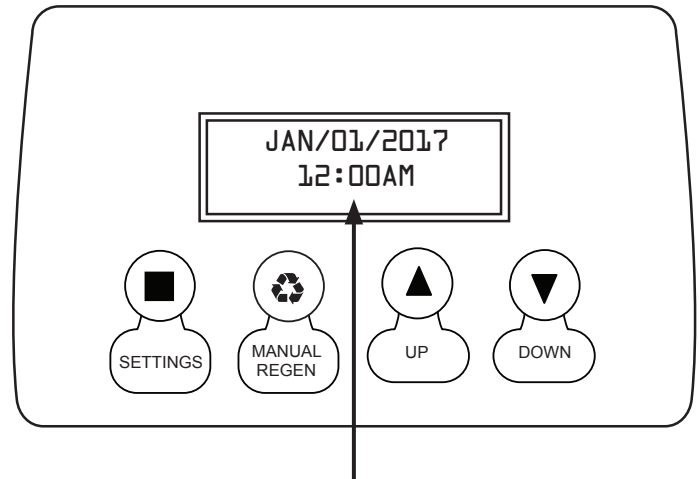

The controller will show the following on the screen - Time, Date and number of Days Remaining for Regeneration.

When power is supplied to the control, the screen may display "INITIALIZING WAIT PLEASE" while it finds the service position.

Key Pad Configuration



SETTINGS

This function is to enter the basic set up information required at the time of installation.



MANUAL REGEN

This function is to initiate an immediate or delayed manual regeneration.

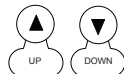

DOWN / UP

Increase or decrease the value of the settings while in the programming mode.

4. Manually Regenerate the Valve

NOTE All units are factory programmed for the correct size and regeneration cycle alteration should only be done by a factory trained technician or after consultation with one of our technical representatives if you have any questions please call: 1-877-288-9888**

- 4a. Open the inlet on the bypass valve slightly and very slowly allow water to enter the unit. (If the water enters too quickly it will push the media up into the control valve and get plugged).

Once the unit has filled sufficiently that water is at least equal to the height of the top of the media shut down the water for 15 – 20 minutes for the media bed to soak. Unplug the power cable. After the media bed has soaked for the recommended time continue.

- 4b. Open the inlet on the bypass valve slowly and allow water to enter the unit. (The outlet of the bypass should remain closed to prevent any fines or debris from entering the plumbing system. Allow all air to escape from the unit before turning the water on fully then allow water to run until the drain water appears to be clear of any fines.
5. Plug in the valve and the valve will automatically advance to the SERVICE position. Open the outlet valve on the bypass, then slowly open the nearest treated water faucet and allow the water to run until clear, close the tap and replace the faucet screen.
6. The Valve is already programmed by the factory. Please continue with set up of current time and hardness.

STARTUP INSTRUCTIONS (CONTINUED)

5. Power and Program Valve

Key Pad Configuration

SETTINGS This function is to enter the basic set up information required at the time of installation.

MANUAL REGEN This function is to initiate an immediate or delayed manual regeneration.

DOWN / UP Increase or decrease the value of the settings while in the programming mode.

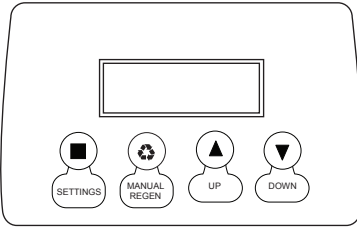

Settings

Press **SETTINGS** key
(3 SECONDS / BEEP)

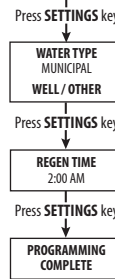
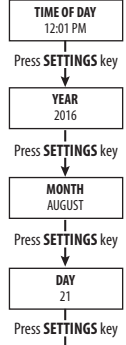

SALT SETTING

Choose **HIGH EFFICIENCY** to minimize salt usage. Your system will regenerate a little more often but your salt usage can be reduced by 20% compared to the **STANDARD** setting. Choose **STANDARD** when you need to maximize your capacity but still operate the system with good efficiency. Choose **IRON & MN** if you have problem water containing these minerals. The high salt setting will be needed since these minerals are more difficult to clean out of the resin bed. Note: A resin cleaner will also need to be periodically added to the brine tank to insure proper operation.

WATER TYPE

This setting will determine if the **BACKWASH OVERRIDE** function will be on or off. Select **MUNICIPAL** if the water source is clean (<1NTU turbidity) and the system will skip the back wash cycle based on the setting in **BACKWASH OVERRIDE**. Select **WELL / OTHER** if any Iron or Manganese is present or if the water source is not clean (< 1NTU turbidity). The system will back wash every time. This setting determines the time of day to perform a scheduled regeneration.

Initial Manual Regen by pressing **SET/REGEN** button. When in backwash cycle, do not skip the cycle and let all air from the tank escape.

After backwash cycle, the valve will advance to brine draw which needs to be skipped by pressing **SET/REGEN** button.

The valve will now advance to **RINSE CYCLE** which can be skipped. Then valve will advance to refill cycle which should not be skipped. This cycle will let the air out of ejector system of the valve.

6. Add Salt to the Brine Tank

Put 40 kgs of crystal water softener salt in the brine tank. The unit will automatically fill the water to the correct level when it regenerates.

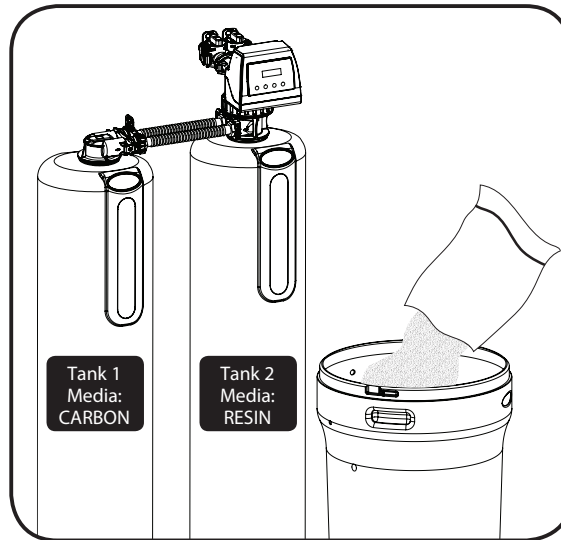

Start up and programming complete. Unit is now operational.

DURING REGENERATION

Automatic Water Bypass

The regeneration cycle lasts approximately 1.5 hours to 3.0 hours depending on the specific model, after which treated water service will be restored. During regeneration, untreated water is automatically bypassed for use in the household. Hot water should be used as little as possible during this time to prevent hard water from filling the water heater.

IMPORTANT: This is why the automatic regeneration is set for sometime during the night and manual regenerations should be performed when little or no water will be used in the household.

Manual Water Bypass

In case of an emergency such as filter maintenance, you can isolate your water filter from the water supply using the bypass valve located at the back of the control. In normal operation the bypass is open with the ON/OFF knobs in line with the INLET and OUTLET pipes. To isolate the filter, simply rotate the knobs clockwise (as indicated by the word BYPASS and arrow) until they lock. You can use your water related fixtures and appliances as the water supply is bypassing the softener. However, the water you use will be hard. To resume treated service, open the bypass valve by rotating the knobs counterclockwise. **Please make sure bypass knobs are completely open otherwise the unfiltered water could bypass through the valve.**

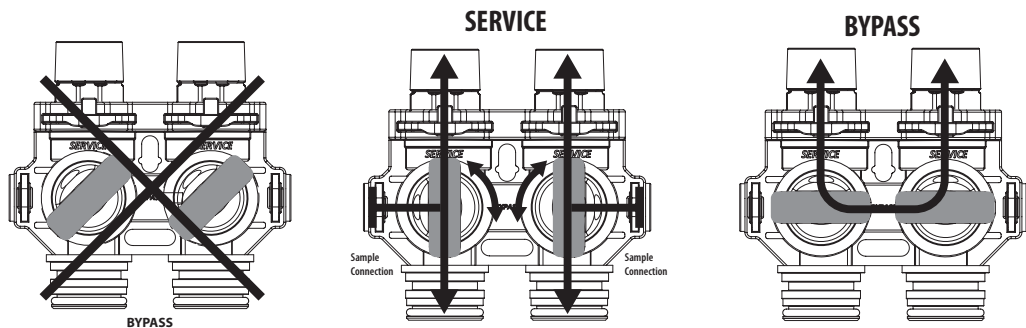

New Sounds

You may notice new sounds as your water softener operates. The regeneration cycle lasts approximately 1.5 hours to 3.0 hours depending on the specific model. During this time, will be able to hear water running intermittently to the drain, depending on proximity of the unit to sleeping area and time of regeneration.

PLUMBING SYSTEM CLEAN-UP

The following procedures are guidelines only but have proven successful in most instances. Under no circumstances should any procedure outlined below be followed if contrary to the appliance manufacturer's instructions. Should there be any questions concerning the advisability of performing a procedure, it is strongly recommended the manufacturer's authorized service outlet be consulted prior to performing the procedure.

Water Heater

If the water heater has been exposed to both iron and hardness for a long period of time, replacement of the heater tank maybe the only practical solution to prevent continued staining originating from this source. After completing the installation of the conditioner, clean the water heater by following these instructions:

1. Shut off energy supply to water heater and close heater inlet water valve.
2. Drain hot water tank completely. Open inlet water valve allowing heater tank to be refilled with iron-free water. Continue flushing until water runs clear to drain.
3. If, after approximately 30 minutes flushing, water does NOT clear, terminate flushing operation. Refill hot water heater with water and pour approximately 1/2 gallon of household bleach into top of heater tank. Allow bleach solution to stand in tank for 20 to 30 minutes. Flush tank

Dishwasher

Consult owners' handbook and follow manufacturer's instructions.

Toilet Flush Tanks

Prior to commencing installation of the filter system, pour 4 to 6 ounces of resin mineral cleaner Pro-Rust Out or other suitable cleaner such as CLR that contains a mild acid into flush tanks and bowls and let stand. When installation is completed, flush toilets several times with conditioned water. If stains or deposits return check that lines are connected to treated water. Repeat procedure until clear. again until water is clear at drain. Turn energy supply on.

NOTE

If water does not clear in approximately 10 minutes, water heater should probably be replaced.



MAINTENANCE INSTRUCTIONS AND SCHEDULE

System Check List

NOTE: Many situations affecting the operation of the product can be diagnosed in only a few minutes. Please review this section before contacting anyone to be sure that there is something wrong with the product and not with the general plumbing system. Please be sure you have reviewed these points before starting up the unit to ensure a successful installation.

1. Check for Proper Installation

- a. Is the inlet line of adequate size and attached to the correct port on the valve?
- b. Is the drain line of adequate diameter? Drain line must be sized to prevent back pressure from reducing backwash flow rate below minimum for the model installed. Typical examples of minimum drain line diameters are:
 - i) 5/8" OD when drain is up to 15 ft from unit and backwash water discharge point is slightly higher than the control valve
 - ii) 3/4" OD when drain is 25 ft away and/or drain is installed overhead
- c. Has the drain line been "kinked"? A kinked drain line must be replaced.
- d. Is the drain line installed in a way that it will freeze in cold weather?

2. Determine Other Uses of Water in Addition to Normal Domestic Purposes

(e.g. geothermal heating or cooling, swimming pool fill, lawn irrigation, farm animal watering, etc.) Have any high demand water uses been added subsequent to the installation of the filter system or overlooked when originally sizing the system? (If a high demand situation exists, resize the system using continuous service flow rate data.)

Service Schedule

- The seals and spacers along with the piston assembly should be inspected/cleaned or replaced every year depending on the inlet water quality and water usage. See inspection and replacement of Piston assembly and seal and spacer kit, page 21, figure 2.
- The injectors should be cleaned/inspected or replaced every year depending on the water quality and use. See Clean Injector Assembly, page 21, figure 3
- SERVICING OF PARALLEL ADAPTOR should be done annually. All connections need to be inspected for leaks, the cross pipes should be removed and inspected for blockage. If there is no evidence of leaking on the adapter no further inspection is required. If additional inspection is required see page 22.
- The media should be replenished or replaced depending of inlet water quality and water consumption. Check with your water treatment expert on the media bed change frequency.
- Maintenance Kit (60010307) should be used for servicing control on an annual basis. The maintenance kit consists of piston assembly, seals and spacers, injectors.

Maintenance of your new water conditioner requires very little time or effort but it is essential. Regular maintenance will ensure many years of efficient and trouble free operation.

FAILURE TO FOLLOW BASIC MAINTENANCE SCHEDULE WILL RESULT IN THE UNIT FAILING TO OPERATE PROPERLY AND VOID YOUR WARRANTY.

Bridging

Humidity or the wrong type of salt may create a cavity between the water and the salt. This action, known as "bridging", prevents the brine solution from being made, leading to your water supply being hard.

If you suspect salt bridging, carefully pound on the outside of the plastic brine tank or pour some warm water over the salt to break up the bridge. This should always be followed up by allowing the unit to use up any remaining salt and then thoroughly cleaning out the brine tank. Allow four hours to produce a brine solution, then manually regenerate the softener.

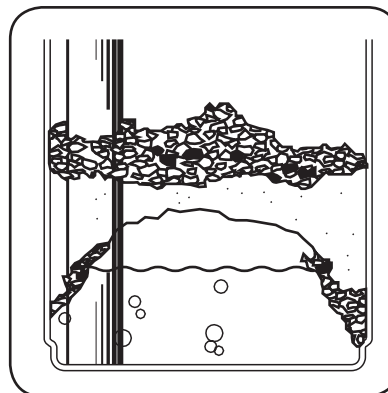

CAUTION!

Liquid brine will irritate eyes, skin and open wounds - gently wash exposed area with fresh water. Keep children away from your water conditioner.

Cleaning of your Brine / Salt tank

Salt tanks will build up sludge (undissolved salt) in the bottom of them that will continue to increase as time goes by. Every 2 - 3 years the salt tank should be cleaned out completely and re started using the original start up instructions.

Never subject your conditioner to freezing, vacuum or to temperatures above 43°C (110°F).

MAINTENANCE INSTRUCTIONS AND SCHEDULE

Checking the Salt Level

Check the salt level monthly. Remove the lid from the cabinet or brine tank, make sure salt level is always above the brine level.

Add Salt to the Brine Tank/Cabinet

Put 40 kgs of crystal water softener salt in the brine tank. The unit will automatically fill the water to the correct level when it regenerates. Use only clean salt labeled for water conditioner use, such as crystal, pellet, nugget, button or solar. The use of rock salt is discouraged because it contains insoluble silt and sand which build up in the brine tank and can cause problems with the system's operation. Add the salt directly to the tank, filling no higher than the top of the brine well.

NOTE :THE WATER LEVEL SHOULD BE BELOW THE SALT LEVEL ALL THE TIME

! CAUTION!

Incorrect start up, water above the salt level, (not enough salt in tank) will both effect the units capacity and result in hardness slippage. Should either of these situations happen or the unit fails to regenerate for any other reason please first correct the problem. Then regenerate the unit manually 2 times in a row to restore the reserve capacity and bring the media bed back up to specification.

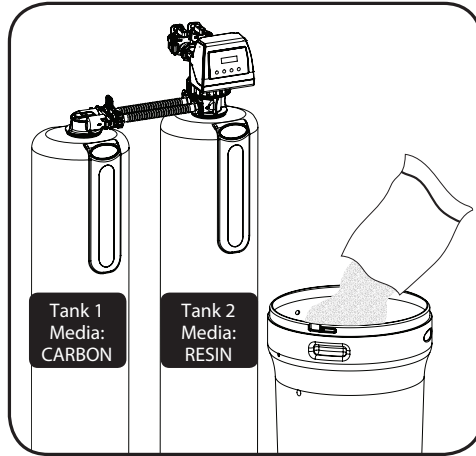
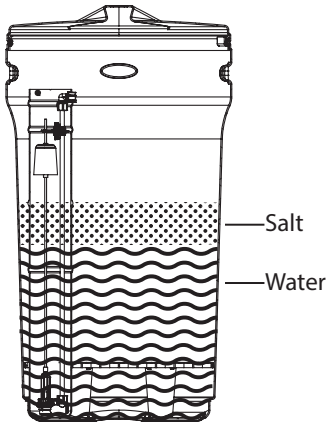

Replacing Media Bed

Frequency of replacing bed is determined by water quality and usage. If you start getting chlorine smell or grey / black coloration of the water from time to time contact your dealer or supplier with your model number to order replacement media.

IMPORTANT WARRANTY AND MAINTENANCE INFORMATION

Please have the information below filled out and available when calling in for parts or warranty:

Model number:
Serial number:
Valve Serial number:
Date installed:

Additional notes:

INSPECTION AND REPLACEMENT OF PISTON ASSEMBLY AND SEAL AND SPACER KIT

Fig. 2

Remove 3 X
Screws

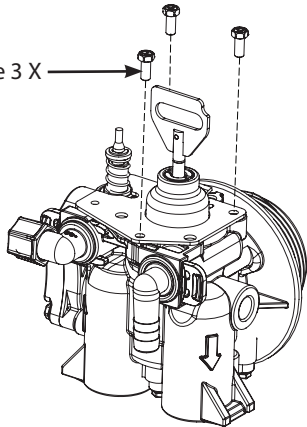

1. Follow steps 1 to 6 of timer /Powerhead replacement.
2. Remove three screws from the plate on the valve body.

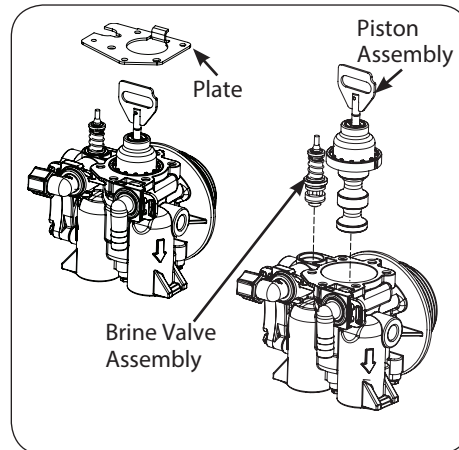

3. Remove the plate from the valve body and pull the Piston Assembly from the valve. The brine valve assembly can also be removed in this stage.
4. Remove the seal spacer assembly, grease it with silicone lubricant (# 92360) and put back in.

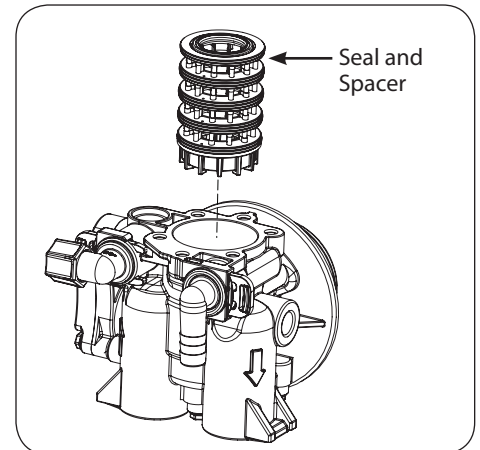

5. Replace piston assembly followed by timer assembly.
6. Replace the piston assembly and reverse following steps in this section

CLEAN INJECTOR ASSEMBLY

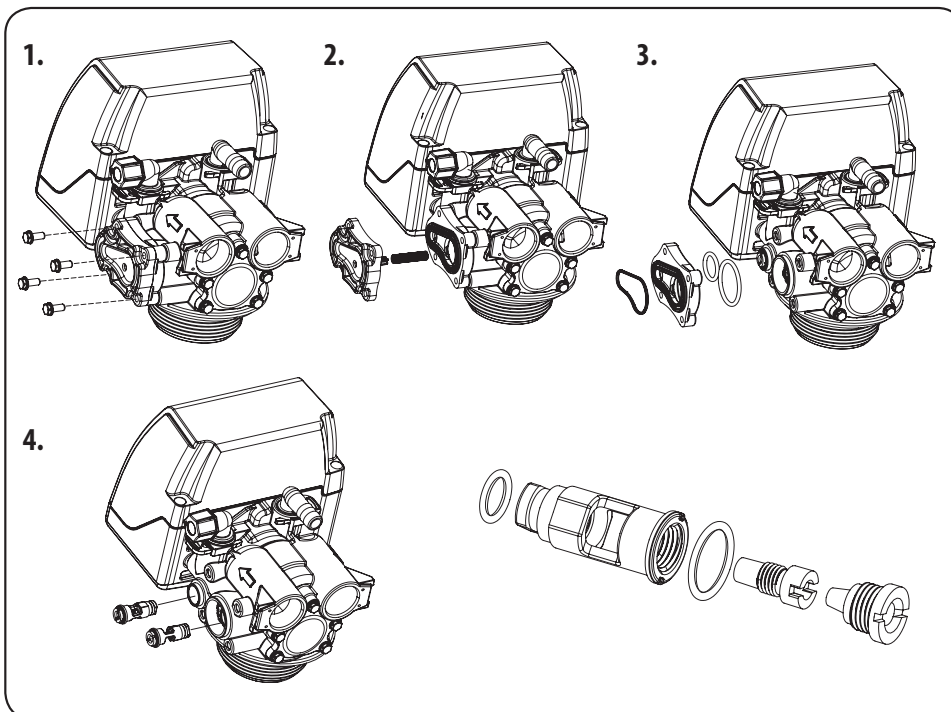

1. Remove four screws of the injector cap.
2. Pull the Injector Cap Out
3. Remove the injector assembly, oring and screen
4. Clean the injectors and replace cap



CAUTION!

Damage to the cage or o-rings can result in the unit not drawing brine, please be careful when reassembling. it is recommended that a replacement set be purchased as a spare to reduce the likelihood of failure due to damage.



WARNING!

ELECTRICAL SHOCK HAZARD! UNPLUG THE UNIT BEFORE REMOVING THE COVER OR ACCESSING ANY INTERNAL CONTROL PARTS

SERVICING OF PARALLEL ADAPTOR

Tank and Valve Connection Parts

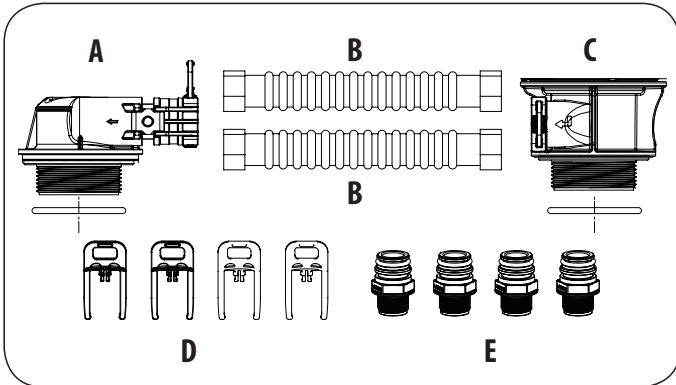

- A. Tank adaptor w/ O ring
- B. Pipe connector - 8" - 12" Tanks
Pipe connector - 14" - 18" Tanks
- C. Parallel tank connector w/ O ring
- D. Red Clips (4pcs)
- E. 1" x 4 Straight, w O ring

NOTE

Full disassembly requires specialty wrenches item's 60010116 and 60010117 and should only be attempted by a qualified service technician. If there is no indication of leaking or fouling of the inlets due to harsh water conditions then there should be no need to disassemble.

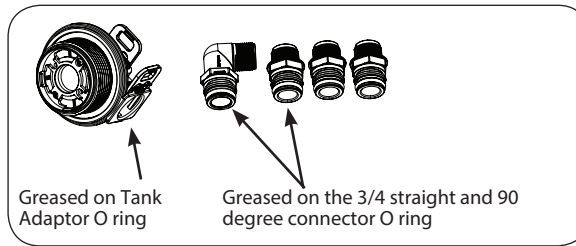
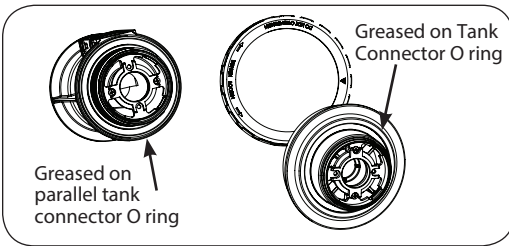

Ensure all Oring on both tank connectors are properly dissembled and apply a good amount of grease.

REPLACE METER ASSEMBLY

1.

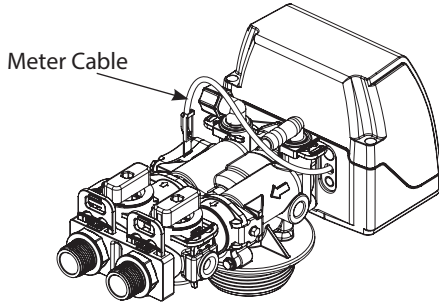

2.

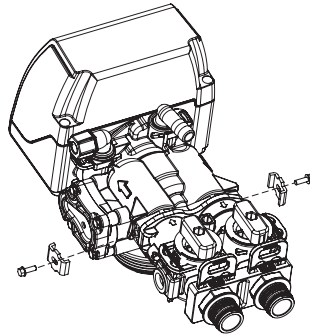

3.

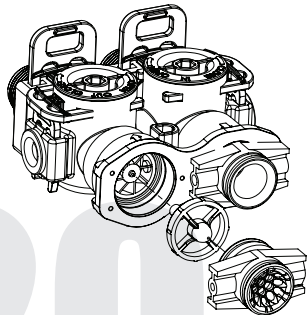
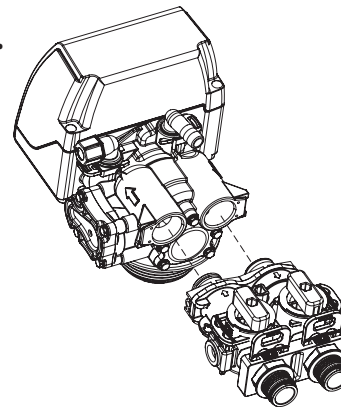

4.

1. Disconnect the meter cable from the meter.
2. Disconnect the valve from bypass by removing clips
3. Remove the coupling adapter from the bypass
4. Remove the meter and meter support from the bypass and replace

REPLACING THE BYPASS AND METER CABLE

If valve is manufactured before March 20th, 2018, and customer wishes to replace or service impeller on bypass. Customer can order 60010238. If customer wishes to replace to new design, then follow the steps below.

60095101 Bypass comes with Meter and Grey Meter Cable

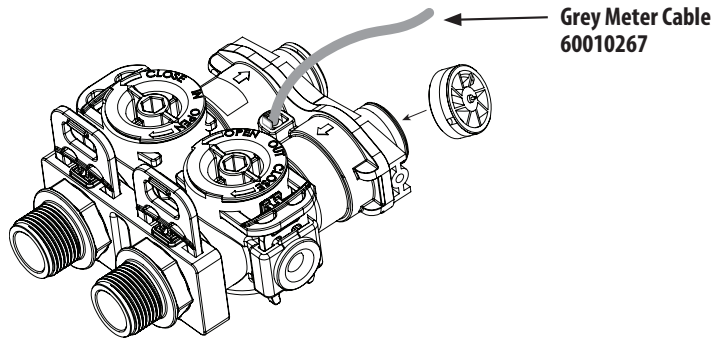

Step 1
Unplug the power from the wall socket.

Step 2*
Remove 2 screws and clips from bypass.

***NOTE**
Water to the household needs to be turned off and pressure relieved before Step 2

Disconnect the meter cable from the bypass.

Step 3
Remove Cover.

Step 4
Disconnect the cables from the front PCB display.

Step 5
Disconnect the cables from the rear PCB display.

Remove the meter cable attached on Main PCB.

Cut the tie that fastens the wires

Step 6
Remove strain relief with pliers.

Step 7
Replace the old cable with the new Cable.

Step 8
Assemble the valve. Plug the power supply back into the wall socket and follow the programming shown on right:

If there are "TB-L" and "TB-H" meter type options in PCB programming, select "TB-H".
If the valve programming has no "TB-L" and "TB-H" options, change the meter ratio to the new value as per chart on right*:
Press the SET to step through to PROGRAMING COMPLETE and past this until TIME OF DAY screen appears.

***Meter and Cable Ratio**

Valve Model	Region	Meter Ratio	
		(OLD) Before March 20th 2018	(NEW) After March 20th 2018
485HE Series	U.S Gallon	8.000	5.680

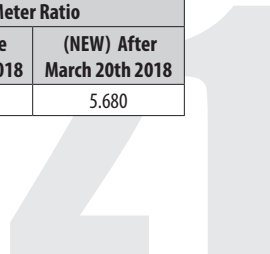

REPLACE MOTOR

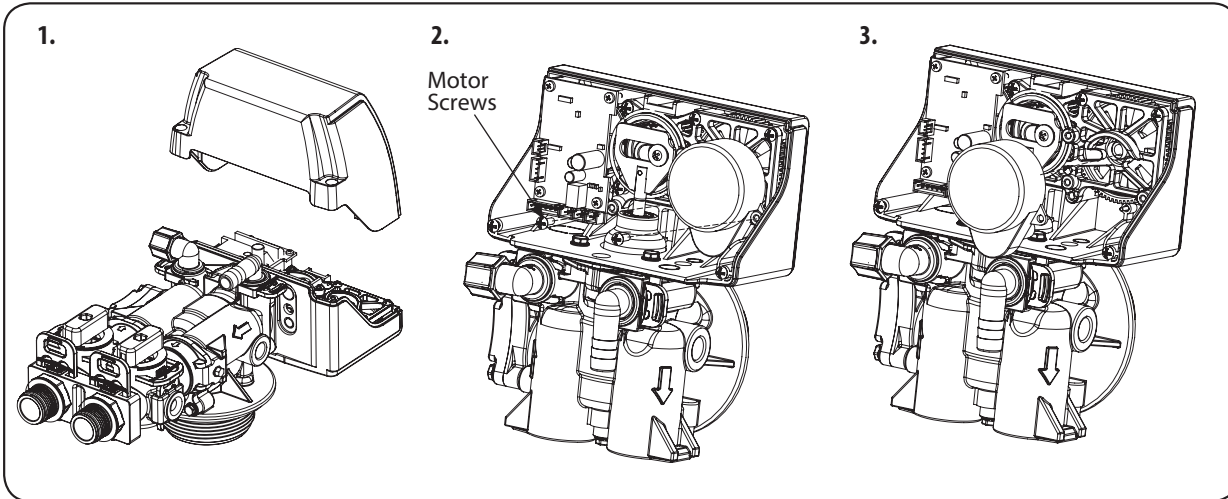

1. Pull the powerhead cover
2. Remove all connections from the circuit board
3. Remove the motor screws and pull the motor out from powerhead

REPLACE DRAIN LINE FLOW CONTROL

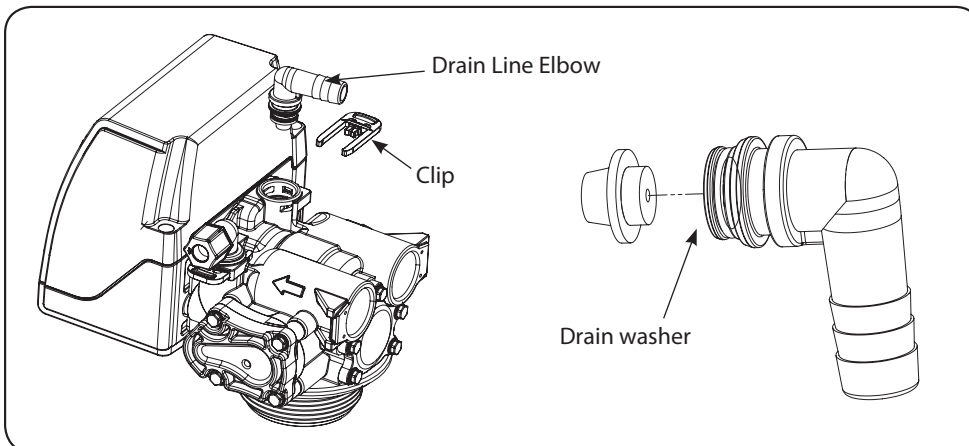

1. Pull the drain line clip and remove the drain line elbow and washer
2. Clean/replace drain line washer

NOTE

Be sure to shut off any bypass line.

REPLACE BRINE LINE FLOW CONTROL

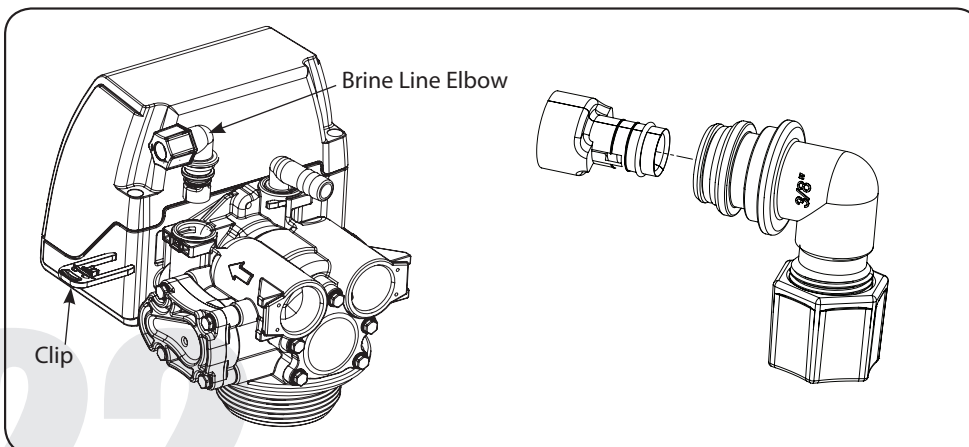

REPLACING PCBS

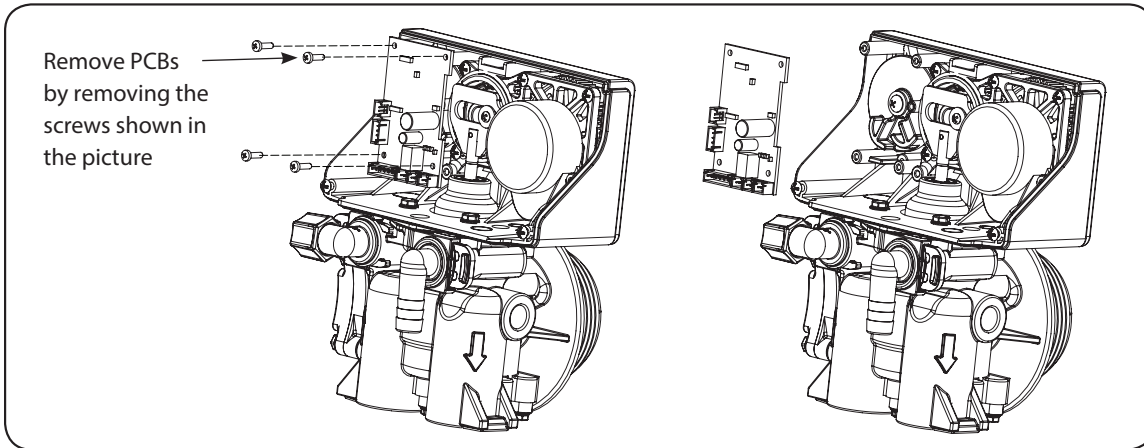

DISPLAY REPLACEMENT

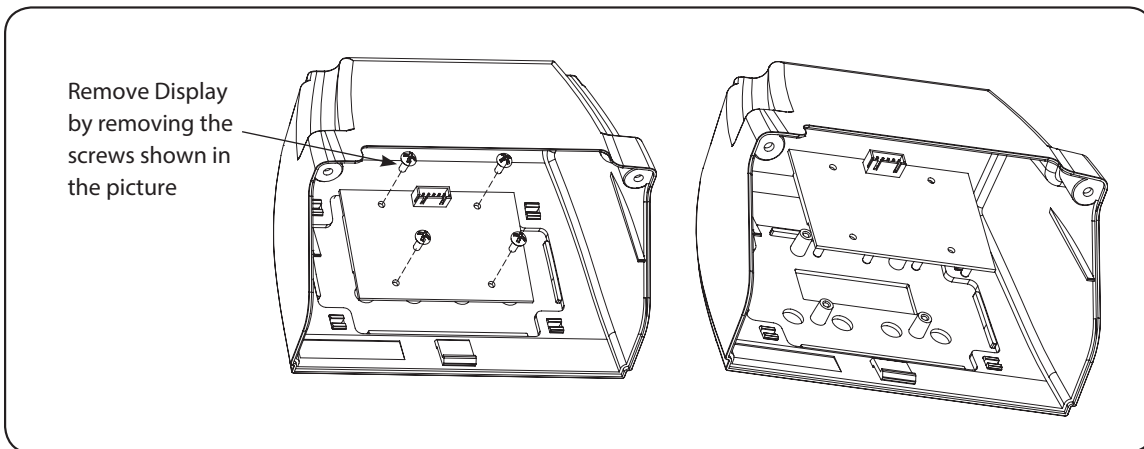

AFTER SERVICING

1. Reconnect drain line
2. Return bypass or inlet valve to normal in service position. Water Pressure will automatically build in the filter
3. Check for leaks at all sealed areas. Check Drain seal with the control in the backwash position
4. Plug electrical cord into outlet
5. Set Time of Day and cycle the control valve manually to assure proper function. Make sure control valve is returned to the In Service position

PARTS BREAKDOWN

Control Valve

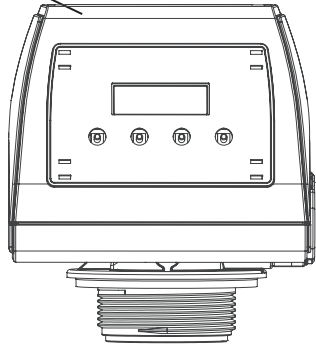

Straight Connector 1" - 60090003
Elbow Connector 1" - 60090026

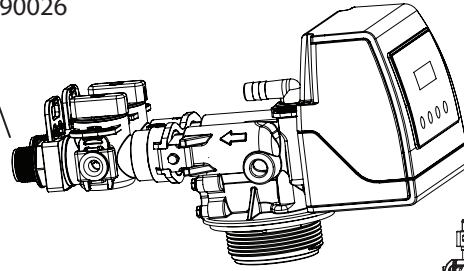

Bypass - Part # 60095101

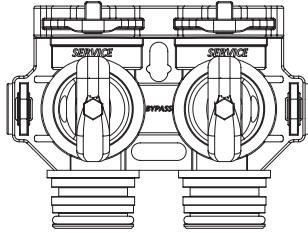

Part # 60010068M

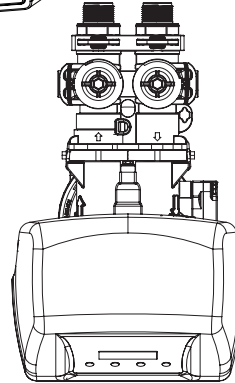

Part # 60010012S

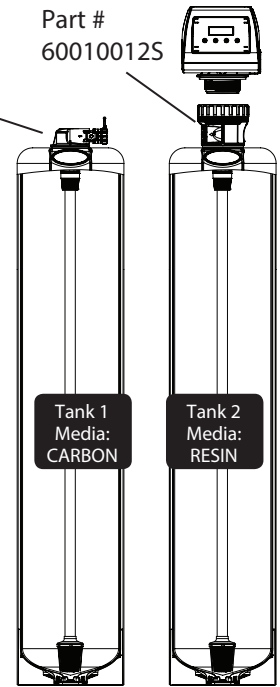

Model	Mineral Tank 1 Size	Tank 1 Media	Tank 2 Media	Distributor#	Valve #
100	9x48	CARBON	RESIN	50010006	10010044
150	10x54	CARBON	RESIN	50010005	10010044
200	12x52	CARBON	RESIN	50010005	10010044
250	13x54	CARBON	RESIN	50010005	10010044
300	14x35	CARBON	RESIN	50010010	10010044

Tank Adaptor W/Oring Part # 60010068M

Parallel Tank Adaptor W/ Oring Part #60010012S

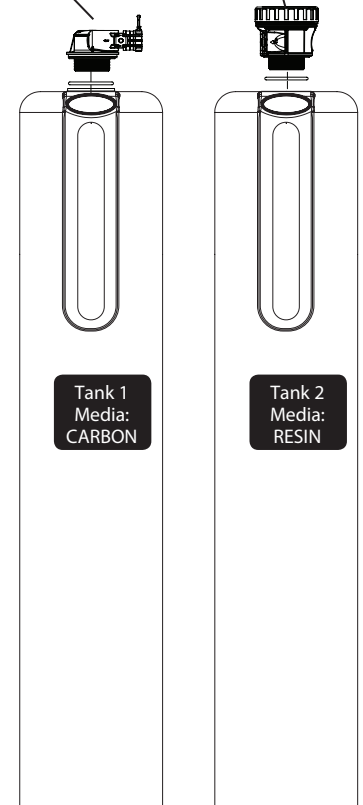

TANK ONE CARBON

Model	Mineral Tank Size	Tank # (Natural Color)	Tank # (Black Color)	Tank # (Blue Color)	Distributor#	Valve #	Media Bed #
Softener Downflow (Single Tank)							
75	8 x 44	25010025	25010027	25010026	50010005	10010060	95401
100	9 x 48	25010034	25010036	25010035	50010005		95401
150	10 x 54	25010049	25010051	25010050	50010005		95402
200	12 x 52	25010058	25010060	25010059	50010005		95403
250	13 x 54	25010064	25010066	25010065	50010010		95403
300	14 x 65	25030001 and 50040039	Not Available	Not Available	50010010		95404

TANK TWO RESIN

Model	Mineral Tank Size	Tank # (Natural Color)	Tank # (Black Color)	Tank # (Blue Color)	Distributor#	Valve #	Media Bed #
Softener Downflow (Single Tank)							
75	8 x 44	25010025	25010027	25010026	50010005	10010060	95600
100	9 x 48	25010034	25010036	25010035	50010005		95601
150	10 x 54	25010049	25010051	25010050	50010005		95606
200	12 x 52	25010058	25010060	25010059	50010005		95609
250	13 x 54	25010064	25010066	25010065	50010010		95610
300	14 x 65	25030001 and 50040039	Not Available	Not Available	50010010		95604

PARTS BREAKDOWN

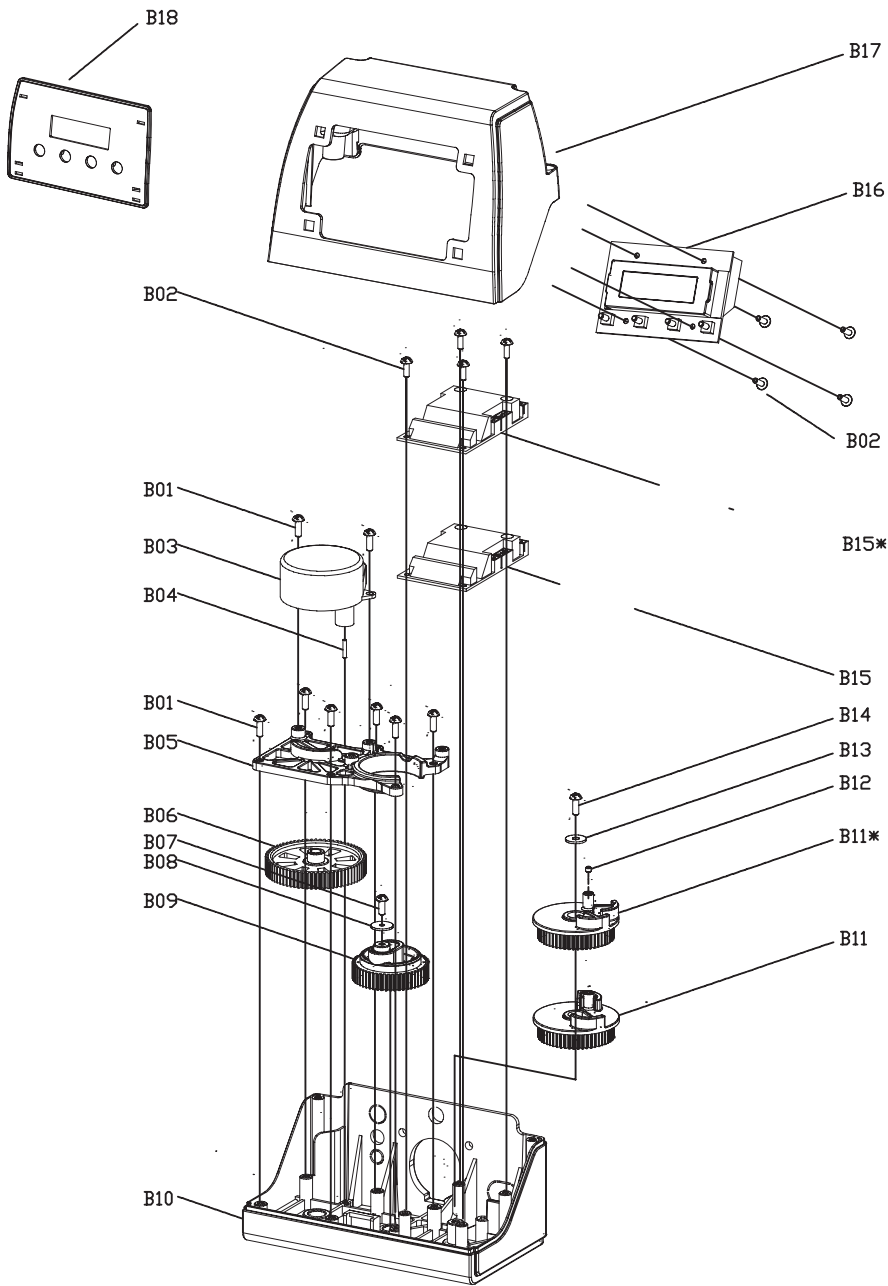

Powerhead Parts List

No.	Part # (Water group)	Description	Qty
B18	60095098	485 Display Plate(Novo)	1
B17	60010141	485 Cover(Novo)	1
	60010240	BNT85 Wiring Harness	1
B16	60010180	BNT85HE PCB (Upflow)	1
	60095099	Wire Rope-3x100	1
	60095091	Power Strain Relief	1
	60010124	Power Cable	1
	60095092	Meter Strain Relief	1
	60010115	Meter Assembly	1
B15*	60010178	485HE Main Pcb(Upflow)	1
B15	60010179	485HE Main Pcb(Downflow)	1
B14	60010575	Screw-4.2x12	1
B13	60010661	Washer-4x12	1
B12	60010661	Magnet(3x2.7)	1
B11*	60095095	BNT85HE Brine Gear(Upflow)	1
B11	92392	BNT85HE Brine Gear(Downflow)	1
B10	60095077	BNT85 Mounting	1
B09	92391	BNT85HE Main Gear	1
B08	60010100	Washer-3x13	1
B07	60010099	Screw-ST2.9X13(Large Washer)	1
B06	00092389	BNT85 Drive Gear	1
B05	60010573	BNT85HE Mounting Plate	1
B04	60010660	Motor Pin	1
B03	92393	Motor	1
B02	60010673	Screw-ST2.9X10	8
B01	60010574	Screw-ST3.5X13	10

PARTS BREAKDOWN

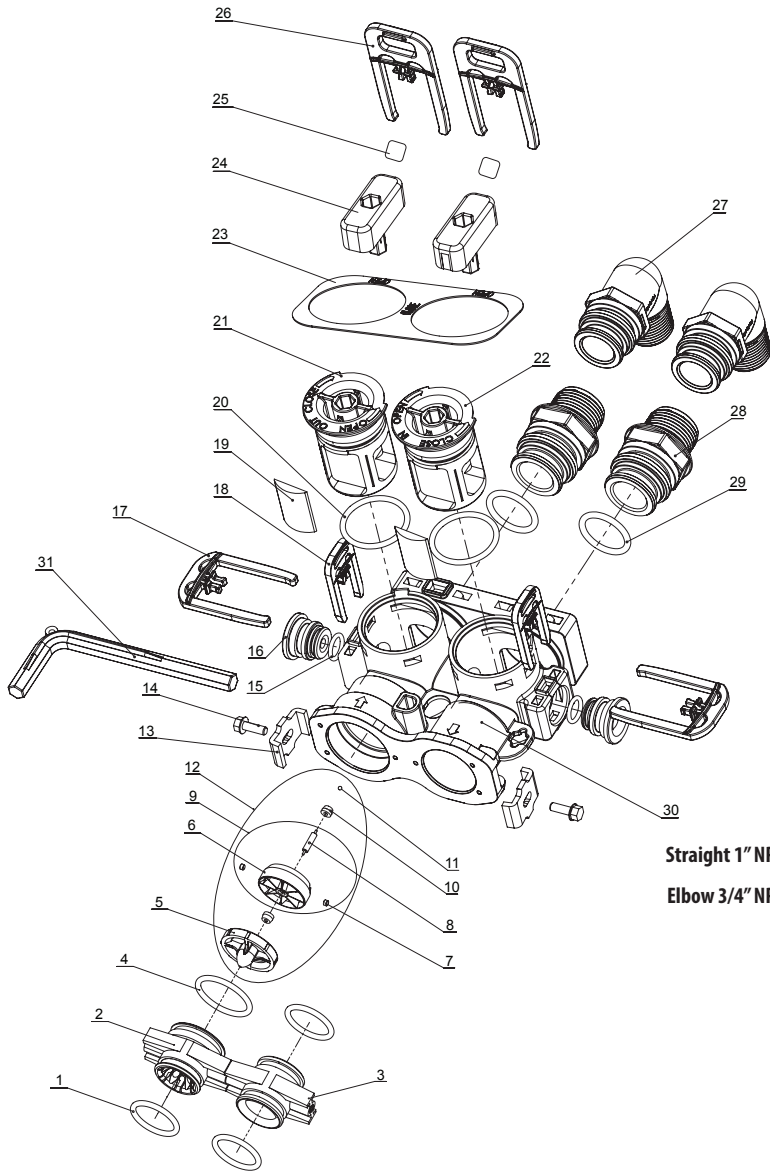

Straight 1" NPT with Oring
Elbow 3/4" NPT with Oring

Bypass Parts List

No.	Part # (Water Group)	Part # (Canature)	Description	Qty
C28	60010006	70020007	Bypass Tool	1
C27		05056212	063 Bypass Body	1
C26	60010026	26010143	O-ring on Inlet and Outlet	2
C25	60010019	21319011N	Straight 1" NPT Inlet and Outlet	2
C24	60010023	21319036N	Elbow 3/4" NPT Inlet and Outlet	2
C23	60010025	21709003N	Secure Clip Inlet and Outlet	2
C22	60010740	50040086	Direction Indication Label	2
C21	60010741	05056220	Bypass Knob	2
C20	60010742	61045012	Bypass Indication Plate	1
C19	60095088	05056214	Bypass Shaft(Outlet)	1
C18	60095089	05056213	Bypass Shaft(Inlet)	1
C17	60095614	05030013	O-ring on Shaft	2
C16	60095051	05056149B	Shaft Seal	2
C15	92846	05056155N	Plug Clip	2
C14	60095090	21709004B	Shaft Clip	2
C13	60010209	05056146	Bypass Plug	2
C12	60010044	05056134	O-ring on Plug	2
C11	60010701	13000327	Screw on SS Clip	2
C10	60010046	05056044B	SS Clip	2
C9		05010019	Bush	2
C8		05010079	Impeller Pin	1
C7	60010238	05010078	Magnet	2
C6		05010014	Impeller	1
C5	60010102	26010046	Big O-ring on Connector(Outlet)	1
C4	60010587	05010077	Impeller Support	1
C3	60010079	05056025M	Valve-Bypass Connector(Inlet)	1
C2	60010101	05010083N	Valve-Bypass Connector(Outlet)	1
C1	60010562	05056129	Small O-ring on Connector(Outlet)	3

PARTS BREAKDOWN

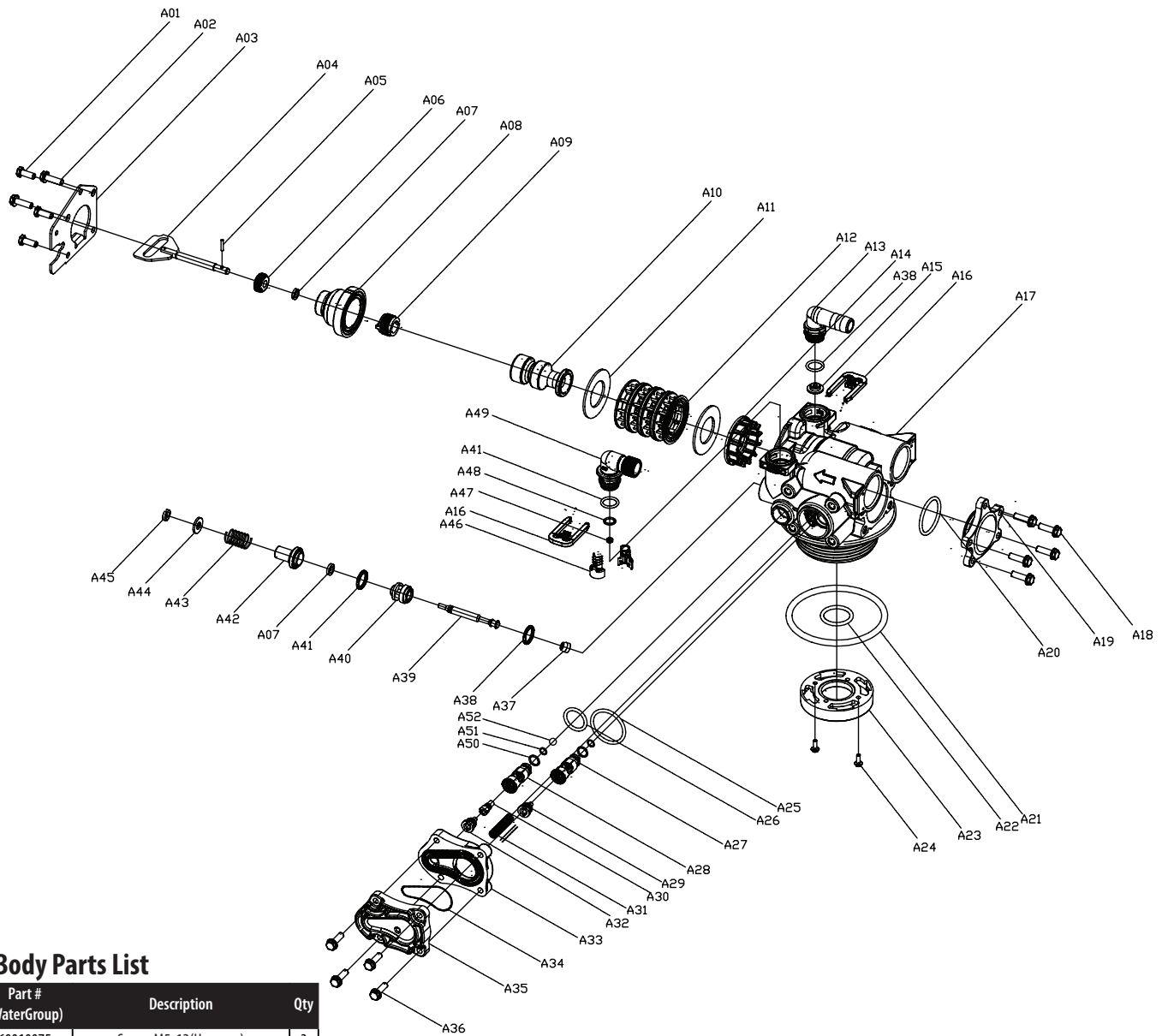

Valve Body Parts List

No.	Part # (WaterGroup)	Description	Qty
A01	60010075	Screw-M5x12(Hexagon)	3
A02	60010076	Screw-M5x16(Hexagon With Washer)	2
A03		End Plug Retainer	1
A04		BNT85HE Rod	1
A05		Piston Pin	1
A06	13446	BNT85HE Quad Ring Plug Cover	1
A07		Quad Ring	2
A08		BNT85HE End Plug	1
A09		BNT85HE Piston Retainer	1
A10		BNT85HE Piston(Down flow)	1
A11	13242-02	Seal	5
A12	14241	Spacer	8
A13	60010229	Drain Fitting-B	1
A14		BNT85HE Spacer	1
A15		DLFC(optional)	1
A16	60010069	Secure Clip-s	2
A17		BNT85HE Valve Body	1
A18		Screw-M5x12(Hexagon With Washer)	5
A19		BNT85 End Cover	1
A20		O-Ring-c30x2.65	1
A21	60010077	O-Ring-c78.74x5.33	1
A22	60010080	O-Ring-c25x3.55	1
A23		Valve Bottom Connector	1
A24	60010099	Screw-ST2.9X13(Large Washer)	2

No.	Part # (WaterGroup)	Description	Qty
A25	60010190	O-Ring-c32x3	1
A26	60010189	O-Ring-c18x3	1
A27	60010174	Injector Plug Body	1
A28		BNT85HE Injector Fixed Sleeve	1
A29	60010175	Injector Plug	1
A30		Injector Throat(optional)	1
A31	10227	Injector Screen	1
A32		Injector Nozzle(optional)	1
A33	60010193	BNT85HE Injector Cover Body	1
A34	60010195	O-Ring-c40x2.65	1
A35	60010194	BNT85HE Injector Cover Cap	1
A36	60010196	Screw-M5x25(Hexagon with Washer)	4
A37		Seal Mat	1
A38		O-Ring-c12x2	3
A39		Injector Stem	1
A40		Injector Spacer	1
A41	92381	O-Ring-c12.5x1.8	1
A42		Injector Cap	1
A43		Injector Screen	1
A44		Spacer Washer	1
A45		Retaining Ring	1
A46	60010173	BNT85HE BLFC Fixed Sleeve	2

No.	Part # (WaterGroup)	Description	Qty
A47		BLFC(optional)	1
A48	60010188	O-Ring-c8x1	1
A49	60010172	BNT85HE Brine Line Elbow	1
A50	60010186	O-Ring-c12.5x1.5	2
A51	60010187	O-Ring-c8x1.5	2
A52		Seal Ball	1

PARTS BREAKDOWN

Tank and Valve Connection Part #s

No.	Part #	Part Description	Qty
A	60010068M	TANK ADAPTOR W/ O RING	1
B	80127819	PIPE CONNECTOR - 8" - 12" TANKS	1
	80127817	PIPE CONNECTOR - 14" - 18" TANKS	1
C	60010012S	PARALLEL TANK CONNECTOR W/ O RING	1
D	60010025	RED CLIPS (4PCS)	4
E	60010016	O RING	4
	60010026	1" BSP STRAIGHT	4

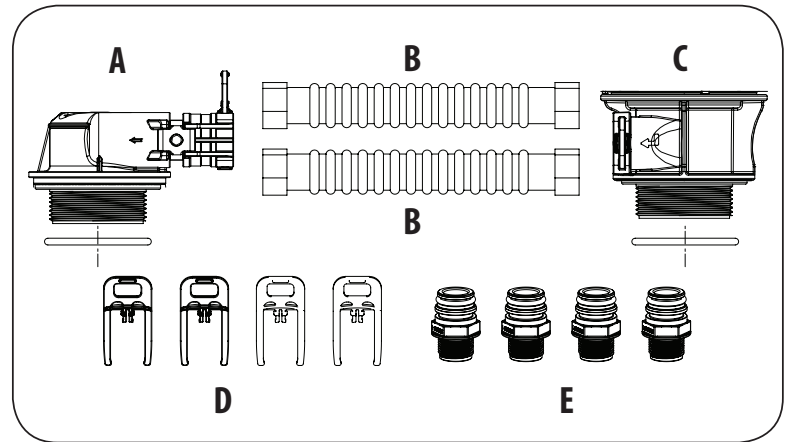

60010012S - Parallel Tank Connector Part #s

No.	Part #	Part Description	Qty
10	60010599	TOP CONE CONNECTOR	1
9	60010080	O-RING $\Phi 25 \times 3.55$	1
8	60010099	SCREW 2.9 \times 13	2
7	60010077	O-RING $\Phi 78.74 \times 5.33$	1
6	60010025	RED CLIPS	2
5	DNR	CONNECTOR BODY	1
4	60010313	RETAINER RING	1
3	60010073	O-ring $\phi 87.5 \times 3.55$	1
2	DNR	Valve Base	1
1	DNR	Clamp Ring	1

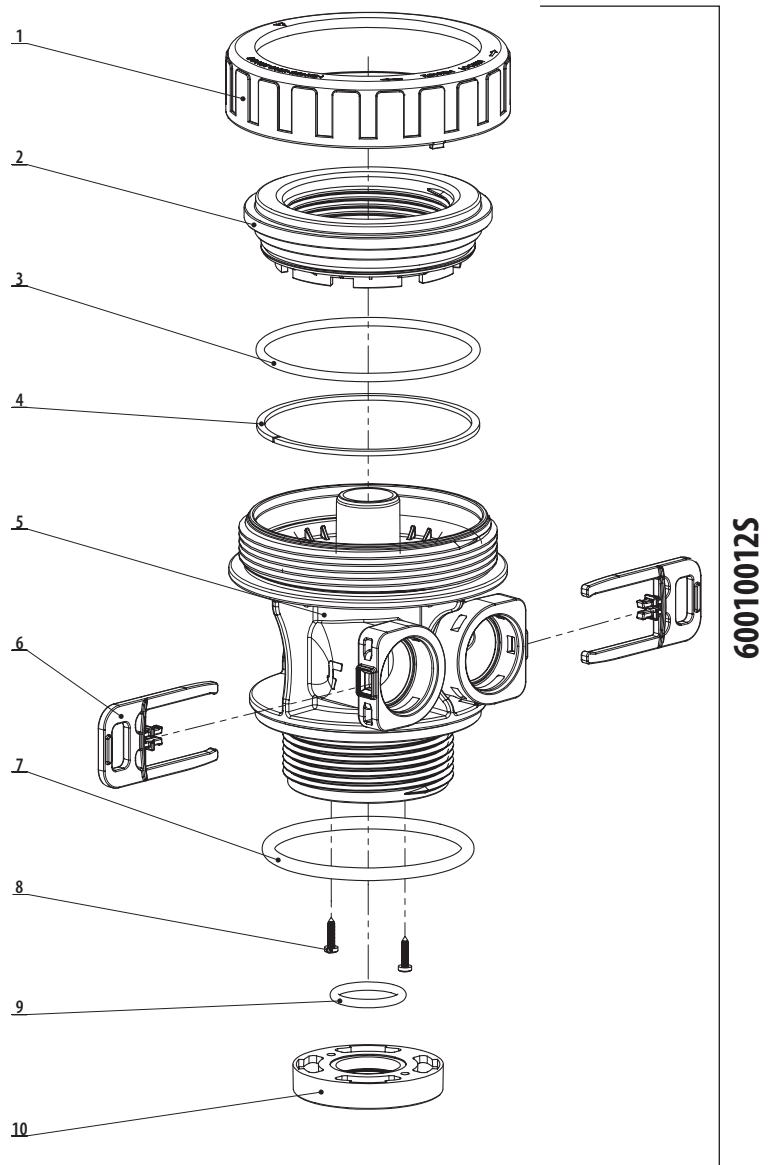

TROUBLE SHOOTING GUIDE

Problem	Possible Solutions
<p>1. CONDITIONER DELIVERS HARD WATER</p> <ul style="list-style-type: none"> A. Bypass valve is open B. No salt in brine tank C. Injector or screen plugged D. Insufficient water flowing into brine tank E. Hot water tank hardness F. Leak at distributor tube G. Internal valve leak H. Flow meter jammed I. Flow meter cable disconnected or not plugged into meter cap J. Improper programming 	<ul style="list-style-type: none"> A. Close bypass valve B. Add salt to brine tank and maintain salt level above water level C. Replace injectors and screen D. Check brine tank fill time and clean brine line flow tank control if plugged E. Make sure distributor tube is not cracked. Check O ring and tube pilot F. Make sure distributor tube is not cracked. Check O ring and tube pilot G. Replace seals and spacers and/or piston H. Remove obstruction from flow meter I. Check meter cable connection to timer and meter cap J. Reprogram the control to the proper regeneration type, inlet water hardness, capacity or flow meter size.
<p>2. CONDITIONER FAILS TO REGENERATE</p> <ul style="list-style-type: none"> A. Electrical service to unit has been interrupted B. Timer is not operating properly C. Defective valve drive motor D. Improper programming 	<ul style="list-style-type: none"> A. Assure permanent electrical service (check fuse, plug, chain or switch) B. Replace timer C. Replace drive motor D. Check programming and reset as needed
<p>3. UNIT USES TOO MUCH SALT</p> <ul style="list-style-type: none"> A. Improper salt setting B. Excessive water in brine tank C. Improper programming 	<ul style="list-style-type: none"> A. Check salt usage and salt setting B. See #7 C. Check programming and reset as needed
<p>4. LOSS OF WATER PRESSURE</p> <ul style="list-style-type: none"> A. Iron build-up in line to water conditioner B. Iron build-up in water conditioner C. Inlet of control plugged due to foreign material broken loose from pipes by recent work done on plumbing system. 	<ul style="list-style-type: none"> A. Clean line to water conditioner B. Clean control and add resin cleaner to resin bed. Increase frequency of regeneration C. Remove piston and clean control
<p>5. LOSS OF RESIN THROUGH DRAIN LINE</p> <ul style="list-style-type: none"> A. Air in water system B. Drain line flow control is too large 	<ul style="list-style-type: none"> A. Assure that well system has proper air eliminator control. Check for dry well condition. B. Ensure drain line flow control is sized
<p>6. IRON IN CONDITIONED WATER</p> <ul style="list-style-type: none"> A. Fouled resin bed B. Iron content exceeds recommended parameters 	<ul style="list-style-type: none"> A. Check backwash, brine draw and brine tank fill. Increase frequency of regeneration. Increase backwash time. B. Add iron removal filter system
<p>7. EXCESSIVE WATER IN BRINE TANK</p> <ul style="list-style-type: none"> A. Plugged drain line flow control B. Brine valve failure C. Improper programming 	<ul style="list-style-type: none"> A. Clean flow control B. Replace brine valve C. Check programming and reset as needed
<p>8. SALT WATER IN SERVICE LINE</p> <ul style="list-style-type: none"> A. Plugged injector system B. Timer not operating properly C. Foreign material in brine valve D. Foreign material in brine line flow control E. Low water pressure F. Improper programming 	<ul style="list-style-type: none"> A. Clean injector and replace screen B. Replace timer C. Clean or replace brine valve D. Clean brine line flow control E. Raise water pressure F. Check programming and reset as needed
<p>9. CONDITIONER FAILS TO DRAW BRINE</p> <ul style="list-style-type: none"> A. Drain line flow control is plugged B. Injector is plugged C. Injector screen is plugged D. Line pressure is too low E. Internal control leak F. Improper programming G. Timer not operating properly 	<ul style="list-style-type: none"> A. Clean drain line flow control B. Clean or replace injectors C. Replace screen D. Increase line pressure (line pressure must be at least 20 psi at all times) E. Change seals and spacers and/or piston assembly F. Check programming and reset as needed G. Replace timer
<p>10. CONTROL CYCLES CONTINUOUSLY</p> <ul style="list-style-type: none"> A. Timer not operating properly B. Faulty hall sensor on circuit 	<ul style="list-style-type: none"> A. Replace timer B. Replace circuit board

TROUBLE SHOOTING GUIDE (CONTINUED)

Problem	Possible Solutions
11. DRAIN FLOWS CONTINUOUSLY A. Foreign material in control B. Internal control leak C. Control valve jammed in brine or backwash position D. Timer motor stopped or jammed teeth E. Timer not operating properly	A. Remove piston assembly and inspect bore. Remove foreign material and check control in various regeneration positions B. Replace seals and/or piston assembly C. Replace piston and seals and spacers D. Replace timer motor and check all gears for missing teeth E. Replace timer

MASTER PROGRAMMING GUIDE

85HE UPFLOW HTO - HTOK SOFTENER FILTER Programming				
MASTER SETTINGS	PRESS & HOLD	♻️ ▲ ▼		
MASTER SETTINGS	100	150	200	300
VALVE TYPE	UPFLOW	UPFLOW	UPFLOW	UPFLOW
SOFTWARE VER.	S1.4 or higher	S1.4 or higher	S1.4 or higher	S1.4 or higher
METER RATIO AFTER MAR 20,2018	5.68	5.68	5.68	5.68
METER RATIO BEFORE MAR 20,2018	8.0	8.0	8.0	8.0
Service Delay	3.0	3.0	3.0	3.0
Backwash Delay	7.0	7.0	7.0	7.0
Brine Delay	4.0	4.0	4.0	4.0
Rinse Delay	5.0	5.0	5.0	5.0
Refill Delay	4.0	4.0	4.0	4.0
MASTER SETTINGS	PRESS & HOLD	■ ♻️		
LANGUAGE = ENGLISH	ENGLISH	ENGLISH	ENGLISH	ENGLISH
UNITS = GALLONS	GALLONS	GALLONS	GALLONS	GALLONS
HIGH EFFICIENCY = 3 LBS	3 LBS	3 LBS	3 LBS	3 LBS
HIGH EFFICIENCY = 4500 GRAINS	4500 GRAINS	4500 GRAINS	4500 GRAINS	4500 GRAINS
STD CAPACITY = 6 LBS	6 LBS	6 LBS	6 LBS	6 LBS
STD CAPACITY = 3600 GRAINS	3600 GRAINS	3600 GRAINS	3600 GRAINS	3600 GRAINS
IRON & MN = 12 LBS	12 LBS	12 LBS	12 LBS	12 LBS
HIGH CAPACITY = 1500 GRAINS	1500 GRAINS	1500 GRAINS	1500 GRAINS	1500 GRAINS
REFILL = 0.2 GPM	0.2 GPM	0.2 GPM	0.2 GPM	0.2 GPM
BRINE MAKE TIME = 30 MIN	30 MIN	30 MIN	30 MIN	30 MIN
BRINE PREFILL %	70%	70%	70%	70%
DAILY RESERVE	75 GAL	75 GAL	75 GAL	75 GAL
BW OVERRIDE	10	10	10	10
FORCED REGEN	OFF	OFF	OFF	OFF
VACATION MODE	OFF	OFF	OFF	OFF
SETTINGS	PRESS & HOLD	■		
TIME OF DAY	SET	SET	SET	SET
YEAR	SET	SET	SET	SET
MONTH	SET	SET	SET	SET
DAY	SET	SET	SET	SET
SET HARDNESS	25	25	25	25
SET PEOPLE	4	4	4	4
SALT SETTING	STANDARD	STANDARD	STANDARD	STANDARD
WATER TYPE	WELL / OTHER	WELL / OTHER	WELL / OTHER	WELL / OTHER
REGEN TIME	2:00 AM	2:00 AM	2:00 AM	2:00 AM
ADVANCED SETTINGS	PRESS & HOLD	▲ ▼		
VALVE MODE	SOFTENER UF	SOFTENER UF	SOFTENER UF	SOFTENER UF
UNIT SIZE	1.0 ft3	1.5 ft3	2.0 ft3	3.0 ft3
SALT SETTING	STANDARD	STANDARD	STANDARD	STANDARD
BACKWASH	4	4	4	4
BRINE	53	53	53	53
RINSE	15	15	15	15
LOCK VALVE	LOCK	LOCK	LOCK	LOCK
VALVE SETUP				
Injector	#0000 BLACK	#0000 BLACK	#00 PURPLE	#1 WHITE
BLFC Washer	0.2 GPM	0.2 GPM	0.2 GPM	0.2 GPM
DLFC Washer	#6 4.0 GPM	#A 5.0 GPM	#B 7.0 GPM	#C 10.0 GPM
Upper Cone	2	2	2	2



MASTER PROGRAMMING GUIDE

Press **Up** and **Down** Button for 3 seconds

Press **MANUAL REGEN** Button and change value using **UP** and **DOWN** Buttons

Key Pad Settings

SETTINGS This function is to enter the basic set up information required at the time of installation.

MANUAL REGEN This function is to initiate an immediate or delayed manual regeneration.

DOWN / UP Increase or decrease the value of the settings while in the programming mode.

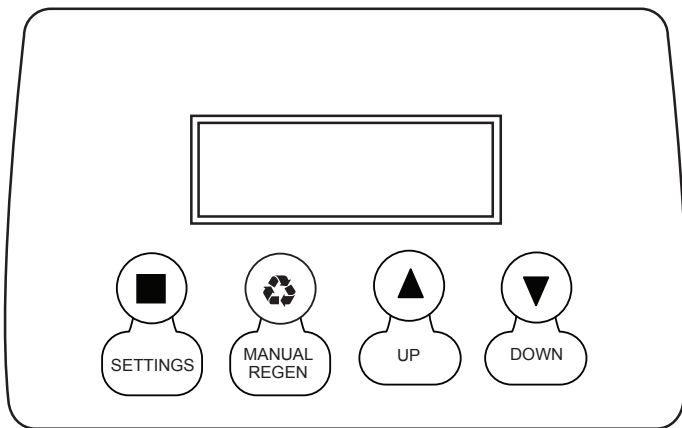

Main Valve Settings

Meter Ratio	5.714
Service Delay	2.0
Backwash Delay	2.0
Brine Delay	2.0
Rinse Delay	2.0
Refill Delay	2.0

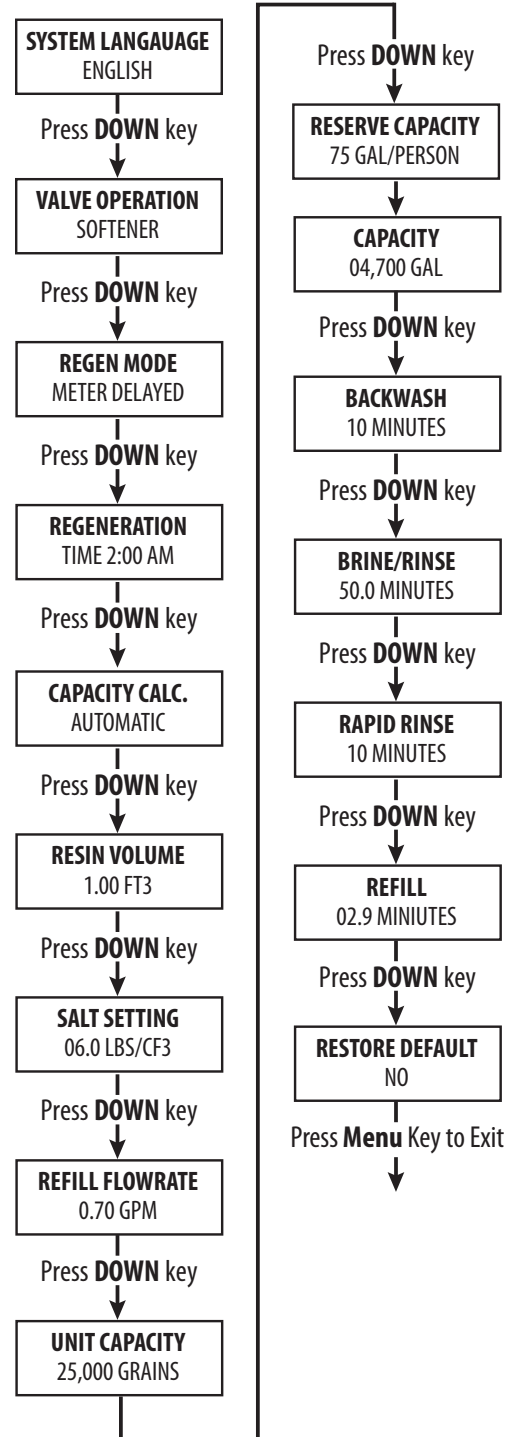

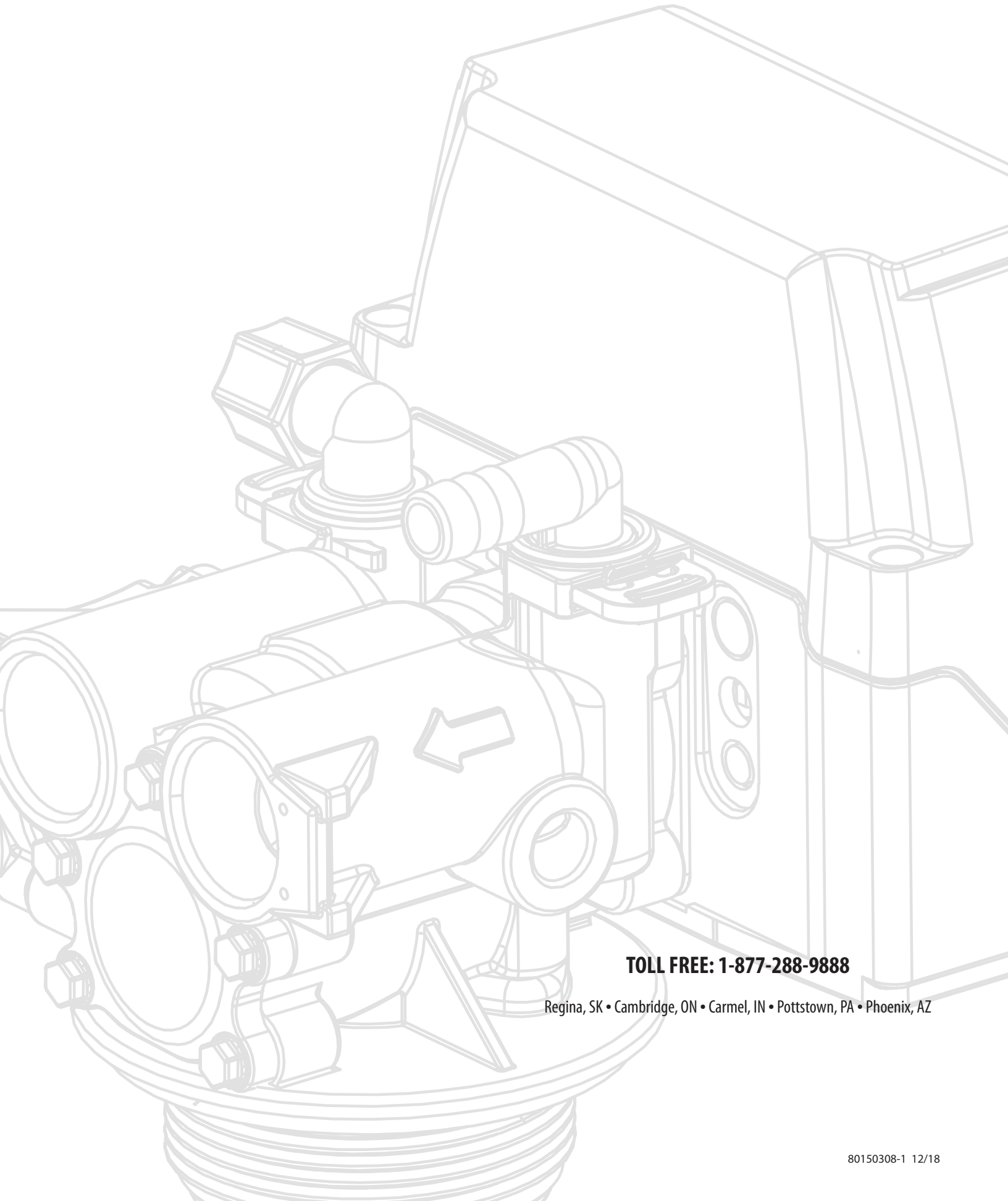

TOLL FREE: 1-877-288-9888

Regina, SK • Cambridge, ON • Carmel, IN • Pottstown, PA • Phoenix, AZ